

PLY GEM WINDOWS *PERSPECTIVE Multi-Slide Patio Door (HVHZ Non-Impact)*

Ply Gem
WINDOWS & DOORS
Part of the Cornerstone Building Brands Family
433 N. MAIN ST.,
PO BOX 559,
ROCKY MOUNT, VA 24151
PH: 540-484-6348
FX: 540-484-6683

NOTES:

- THIS INSTALLATION HAS BEEN EVALUATED FOR USE IN LOCATIONS ADHERING TO THE FLORIDA BUILDING CODE INCLUDING THE HVHZ, AND WHERE PRESSURE REQUIREMENTS AS DETERMINED BY ASCE 7 MINIMUM DESIGN LOADS FOR BUILDINGS AND OTHER STRUCTURES DO NOT EXCEED THE DESIGN PRESSURE RATINGS HEREIN.
- WHEN USED IN AREAS REQUIRING IMPACT PROTECTION, THIS PRODUCT REQUIRES THE USE OF APPROVED IMPACT PROTECTIVE DEVICES (SHUTTERS).
- ANCHOR TYPE, SIZE, SPACING, EMBEDMENT, AND EDGE DISTANCE SHALL BE AS SPECIFIED IN THESE DRAWINGS. USE APPROPRIATE ANCHORAGE FROM TABLE I ACCORDING TO SUBSTRATE TYPE. A MINIMUM CENTER-TO-CENTER SPACING SHALL BE MAINTAINED BETWEEN ALL INSTALLATION FASTENERS IN ANY DIRECTION.
- ANCHOR EMBEDMENT TO SUBSTRATE SHALL BE BEYOND WALL DRESSING OR STUCCO. FOR MASONRY OPENINGS WITH WOOD BUCKS LESS THAN 1-1/2" THICK, EMBEDMENT SHALL BE BEYOND WOOD BUCKS, IF USED, AND INTO MASONRY SUBSTRATE. WOOD BUCKS WITH MASONRY ARE OPTIONAL.
- WOOD, METAL, OR MASONRY OPENINGS, BUCKS, AND BUCK FASTENERS, BY OTHERS, SHALL BE PROPERLY DESIGNED AND INSTALLED BY OTHERS TO TRANSFER SUPERIMPOSED LOADS TO THE STRUCTURE. ADEQUACY OF THE STRUCTURE TO RECEIVED THESE LOADS SHALL BE VERIFIED BY THE CONTRACTOR OR AUTHORITY HAVING JURISDICTION (AHJ).
- IT IS THE RESPONSIBILITY OF THE ARCHITECT OR ENGINEER OF RECORD OR AS APPROVED BY THE AHJ TO SELECT PLY GEM PRODUCTS TO MEET ALL APPLICABLE LOCAL LAWS, BUILDING CODES, ORDINANCES, OR OTHER SAFETY REQUIREMENTS FOR EACH INSTALLATION.
- SHIMS ARE REQUIRED WHERE GAPS OF GREATER THAN 1/16" EXIST BETWEEN OPENING AND FRAME. MAX. SHIM STACK IS 1/4". SHIMS SHALL BE LOAD-BEARING AND CAPABLE OF TRANSFERRING LOADS TO THE SUBSTRATE.
- SEALING AND FLASHING STRATEGIES FOR OVERALL WATER INFILTRATION RESISTANCE OF THE INSTALLED PRODUCT SHALL BE THE RESPONSIBILITY OF OTHERS USING ASTM E 2112 AND IS NOT ADDRESSED BY THIS DOCUMENT.
- INSTALLED GLAZING SHALL COMPLY WITH ASTM E 1300.
- ALL FASTENERS PENETRATING INTO PRESSURE TREATED WOOD SHALL BE CAPABLE OF PREVENTING CORROSION DUE TO REACTION WITH PRESSURE TREATMENT CHEMICALS. ANY DISSIMILAR MATERIALS THAT COME INTO CONTACT SHALL BE PROTECTED TO PREVENT REACTIONS IN ACCORDANCE WITH CODE REQUIREMENTS.
- A WIND LOAD DURATION FACTOR $C_d = 1.6$ WAS USED FOR THE ANALYSIS OF WOOD SCREWS ONLY.
- PRODUCTS SHALL BE CONSTRUCTED AS SPECIFIED IN TEST REPORTS 11835.06/10/11/12/13/14/15/17/18/19/22-106-II-R0, 11835.02/16-106-II-RI, 11835.05/07-106-II-R2 AND 11835.03-106-12-RI BY MOLIMO ARCHITECTURAL PRODUCT TESTING.
- POCKET WALL/CAVITY IS NOT PART OF THIS APPROVAL AND REVIEWED BY THE AUTHORITY HAVING JURISDICTION (AHJ).
- USE A BACKER ROD ON ALL JOINTS $>3/4"$ DEEP AND/OR WIDER THAN $1/4"$. FINISHED CAULK JOINT SHOULD BE A MINIMUM OF $3/8"$ DEEP.

SIZE CHART					
OVERALL FRAME MAX. SIZE		PERFORMANCE RATING	DESIGN PRESSURE	MIN. SILL RISER	INSTALLATION METHOD
WIDTH	HEIGHT				
353"	96"	LC-PG70	+70/-80 PSF	2-1/4"	NAIL FIN OR THROUGH FRAME

PANEL SIZE CHART				
PANEL CALL SIZE	PANEL MAX. SIZE	D.L.O.		GLAZING DETAIL TYPE
		WIDTH	HEIGHT	
3-0 8-0	37-1/8" x 93-1/16"	28-1/8"	84-1/8"	1 OR 2
4-0 8-0	49-1/8" x 93-1/16"	40-1/8"	84-1/8"	1 OR 2
5-0 8-0	61-1/8" x 93-1/16"	52-1/8"	84-1/8"	2

TABLE OF CONTENTS	
SHEET	SHEET DESCRIPTION
1	SIZE CHART, PANEL SIZE CHART & GENERAL NOTES
2	TABLE I
3	CONFIGURATIONS & ELEVATIONS
4	HORIZONTAL SECTION DETAILS
5	VERTICAL SECTION DETAILS
6-24	ANCHOR LAYOUTS
25	P-HOOK ANCHOR LAYOUT DETAILS & TABLE 2
26	GLAZING DETAILS & SPLICE DETAILS
27	NAIL FIN SUPPLEMENTAL PATTERN
28	BILL OF MATERIALS
29	COMPONENTS

TITLE: PERSPECTIVE MULTI-SLIDE PD HVHZ NON-IMPACT SIZE CHART, PANEL SIZE CHART & GENERAL NOTES	DATE	BY	REVISION DESCRIPTION	NO.
	DATE: 09/18/23	DWN BY: LMH	CHK BY: SAS	SCALE: NTS



12/17/2023
LUCAS A. TURNER, P.E.
FL PE # 58201
TURNER ENGINEERING & CONSULTING, INC.
(COA # 29779)
2428 OLD NATCHEZ TRACE
TRAIL, CAMDEN, TN 38320
PH. 941-380-1574

FL#: **41161**

DWG #: **PGW347**

SHEET: **1 OF 29**

PERFORMANCE GRADE LC-PG70 (+70/-80) HVHZ NON-IMPACT

Ply Gem
WINDOWS & DOORS
Part of the Cornerstone Building Brands Family
433 N. MAIN ST.,
PO BOX 559,
ROCKY MOUNT, VA 24151
PH: 540-484-6348
FX: 540-484-6683

TABLE I: INSTALLATION FASTENERS TABLE

ID	FRAME LOCATION	SUBSTRATE TYPE	ANCHOR TYPE	MIN. EDGE DISTANCE	MIN. EMBED.	MIN. ON CENTER SPACING	PANEL WIDTH					
							UP TO 3-0 x 8-0 MAX.		UP TO 4-0 x 8-0 MAX.		UP TO 5-0 x 8-0 MAX.	
							HEAD & SILL CLUSTERS QUANTITY	JAMB O.C. SPACING	HEAD & SILL CLUSTERS QUANTITY	JAMB O.C. SPACING	HEAD & SILL CLUSTERS QUANTITY	JAMB O.C. SPACING
A	HEAD/SILL/JAMB	CONCRETE (2 KSI MIN.)	1/4" ITW TAPCON w/ADVANCED THREADFORM TECHNOLOGY COATED CARBON STEEL	1-1/2"	1-3/4"	4"	3	16-3/4"	4	16-3/4"	5	16-3/4"
B	JAMBS ONLY	HOLLOW OR GROUT-FILLED CMU (ASTM C-90)	1/4" ITW TAPCON w/ADVANCED THREADFORM TECHNOLOGY COATED CARBON STEEL	2"	1"	4"	N/A	9-1/2"	N/A	9-1/2"	N/A	9-1/2"
C	HEAD/SILL/JAMB	CONCRETE (3.05 KSI MIN.)	1/4" DEWALT ULTRACON+, COATED CARBON STEEL	1"	1-3/8"	4"	5	9-1/2"	7	9-1/2"	9	9-1/2"
D	HEAD/SILL/JAMB	CONCRETE (3.05 KSI MIN.)	1/4" DEWALT ULTRACON+, COATED CARBON STEEL	2-1/2"	1-3/8"	4"	3	16-3/4"	3	16-3/4"	3	16-3/4"
E	JAMBS ONLY	HOLLOW CMU (ASTM C-90)	1/4" DEWALT ULTRACON+, COATED CARBON STEEL	1"	1-1/4"	3"	N/A	9-1/2"	N/A	9-1/2"	N/A	9-1/2"
F	JAMBS ONLY	HOLLOW CMU (ASTM C-90)	1/4" DEWALT ULTRACON+, COATED CARBON STEEL	2-1/2"	1-1/4"	3"	N/A	16-3/4"	N/A	16-3/4"	N/A	16-3/4"
G	JAMBS ONLY	GROUT-FILLED CMU (ASTM C-90)	1/4" DEWALT ULTRACON+, COATED CARBON STEEL	1"	1-1/4"	4"	N/A	9-1/2"	N/A	9-1/2"	N/A	9-1/2"
H	HEAD/SILL/JAMB	CONCRETE (3 KSI MIN.)	1/4" HILTI KWIK-CON+, COATED CARBON STEEL	2-1/2"	1"	2"	3	16-3/4"	3	16-3/4"	4	16-3/4"
I	JAMBS ONLY	HOLLOW OR GROUT-FILLED CMU (ASTM C-90)	1/4" HILTI KWIK-CON+, COATED CARBON STEEL	2-1/2"	1"	4"	N/A	9-1/2"	N/A	9-1/2"	N/A	9-1/2"
J	HEAD/SILL/JAMB	CONCRETE (2.22 KSI MIN.)	#1/4" DEWALT AGGRE-GATOR, 300 STAINLESS STEEL	1-1/2"	1-3/8"	3"	3	9-1/2"	4	9-1/2"	6	9-1/2"
K	JAMBS ONLY	HOLLOW OR GROUT-FILLED CMU (ASTM C-90)	#1/4" DEWALT AGGRE-GATOR, 300 STAINLESS STEEL	2"	1-1/4"	3"	N/A	9-1/2"	N/A	9-1/2"	N/A	9-1/2"
L	HEAD/SILL/JAMB	2X MIN. SPRUCE-PINE-FIR WOOD (G>=0.42)	#12 GRADE 5 WOOD SCREW	3/4"	1-1/2"	3"	5	10-1/4"	7	10-1/4"	9	10-1/4"
M	HEAD/SILL/JAMB	2X MIN. SOUTHERN PINE WOOD (G>=0.55)	#12 GRADE 5 WOOD SCREW	3/4"	1-1/2"	3"	5	10-1/4"	7	10-1/4"	9	10-1/4"
N	HEAD/SILL/JAMB	2X MIN. SPRUCE-PINE-FIR WOOD (G>=0.42)	1/4" MASONRY FASTENERS AS LISTED IN THIS TABLE	1"	1-1/2"	3"	5	10-1/4"	7	10-1/4"	9	10-1/4"
O	HEAD/SILL/JAMB	2X MIN. SOUTHERN PINE WOOD (G>=0.55)	1/4" MASONRY FASTENERS AS LISTED IN THIS TABLE	1"	1-1/2"	3"	5	10-1/4"	7	10-1/4"	9	10-1/4"
P	HEAD/SILL/JAMB	16 GAUGE (0.060"), MIN. STEEL STUD, 33 KSI YIELD MIN.	#12-14 ITW TEKS, DEWALT DRIL-FLEX, OR HILTI KWIK-FLEX SELF-DRILLING SCREW	1/2"	FULL PLUS 3 THREADS MIN.	3"	5	10-1/4"	7	10-1/4"	9	10-1/4"
Q	HEAD/SILL/JAMB	1/8" ALUM. 6063-T5 MIN. OR 1/8" STEEL 36 KSI MIN.	#12-14 GRADE 5 SELF-TAPPING/DRILLING SCREW	1/2"	FULL PLUS 3 THREADS MIN.	3"	5	10-1/4"	7	10-1/4"	9	10-1/4"

NOTES: -ALL SCREWS SHALL BE PAN OR HEX WASHER HEAD.
-PRE-DRILLING FOR ANCHORS INTO WOOD IS RECOMMENDED.
-SEE SHEET 25 FOR P-HOOK DETAILS.
-CONCRETE/MASONRY SHALL NOT BE CRACKED.

TITLE: PERSPECTIVE MULTI-SLIDE PD HVHZ NON-IMPACT TABLE I	DATE				
	BY				
	REVISION DESCRIPTION				
NO.					
DATE: 09/18/23	DWN BY: LMH	CHK BY: SAS	SCALE: NTS		

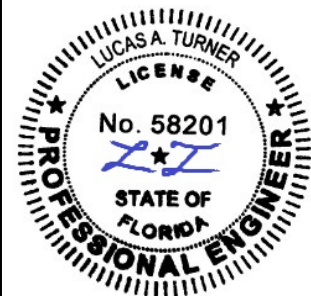

12/17/2023
LUCAS A. TURNER, P.E.
FL PE # 58201
TURNER ENGINEERING & CONSULTING, INC.
(COA # 29779)
2428 OLD NATCHEZ TRACE TRAIL, CAMDEN, TN 38320
PH. 941-380-1574

FL#: **41161**
DWG #: **PGW347**
SHEET: **2 OF 29**

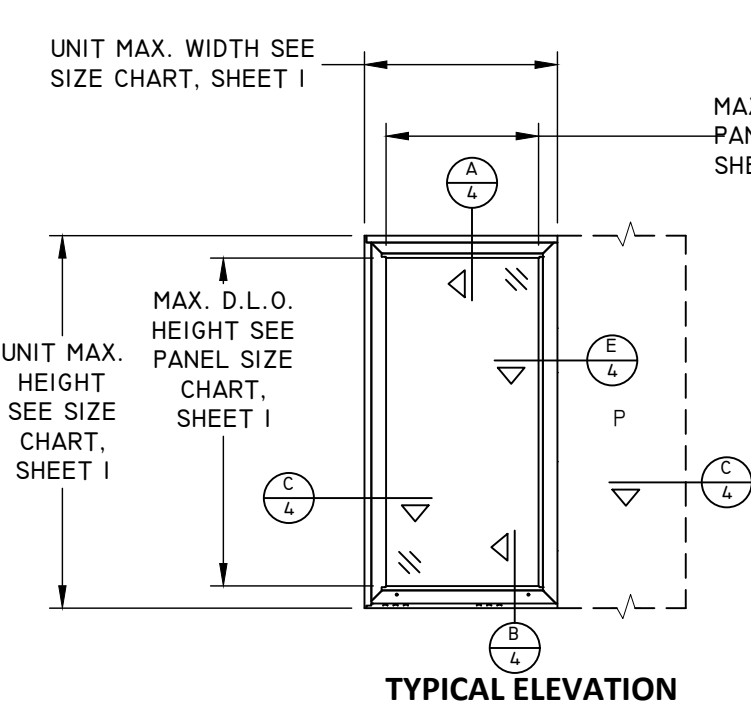

TYPICAL ELEVATION
XP or PX

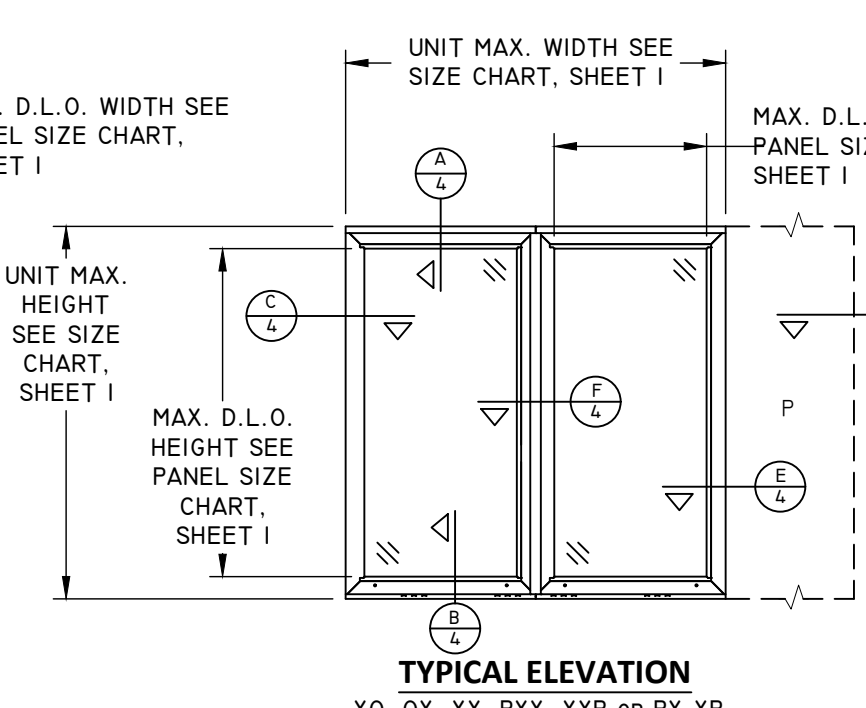

TYPICAL ELEVATION
XO, OX, XX, PXX, XXP or PX-XP

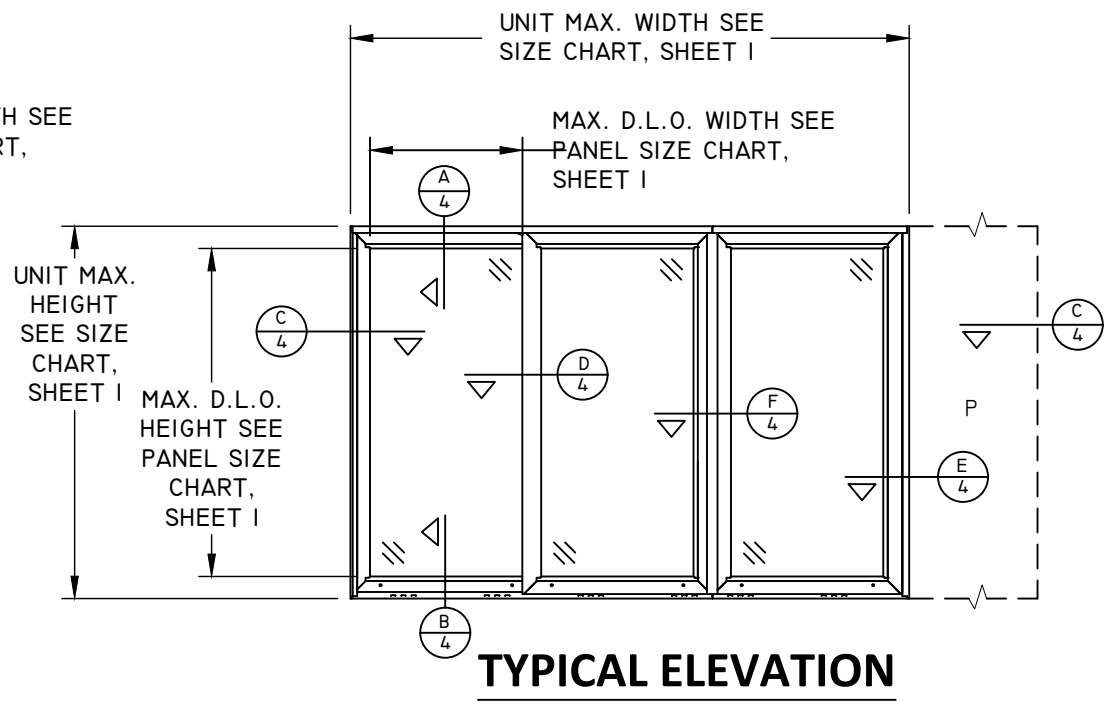

TYPICAL ELEVATION
XXXXP, PXXX, XXXL, XXO, OXX, OX-O or O-XO

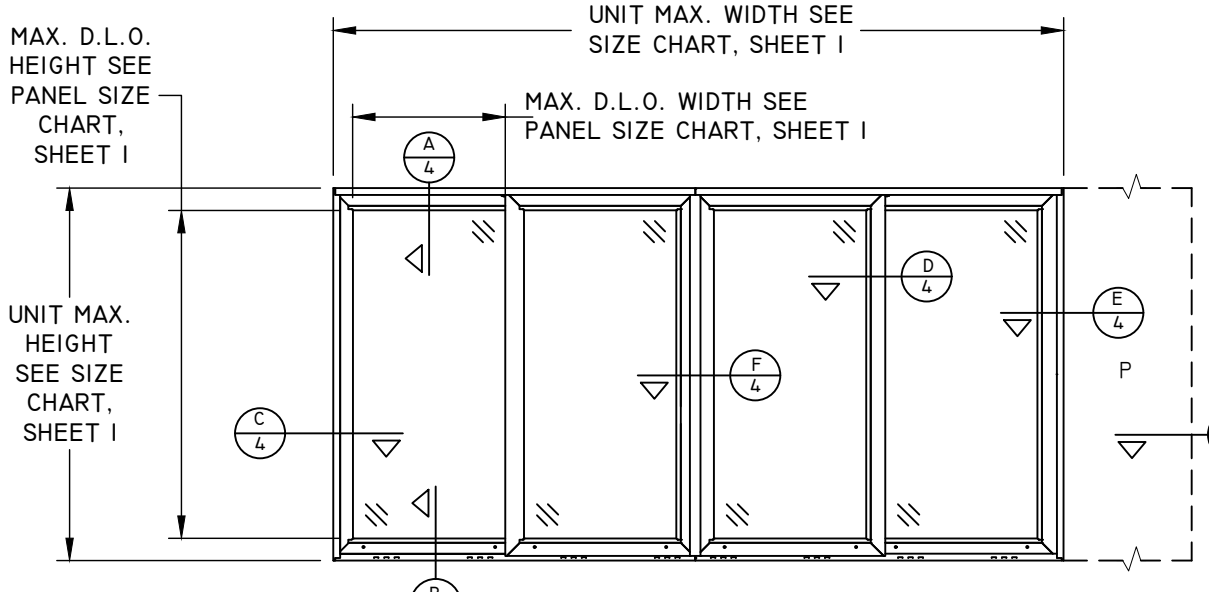

TYPICAL ELEVATION
XXXXP, PXXX, XXXL, XXXO, OXXX, PXX-XXP or OX-XO

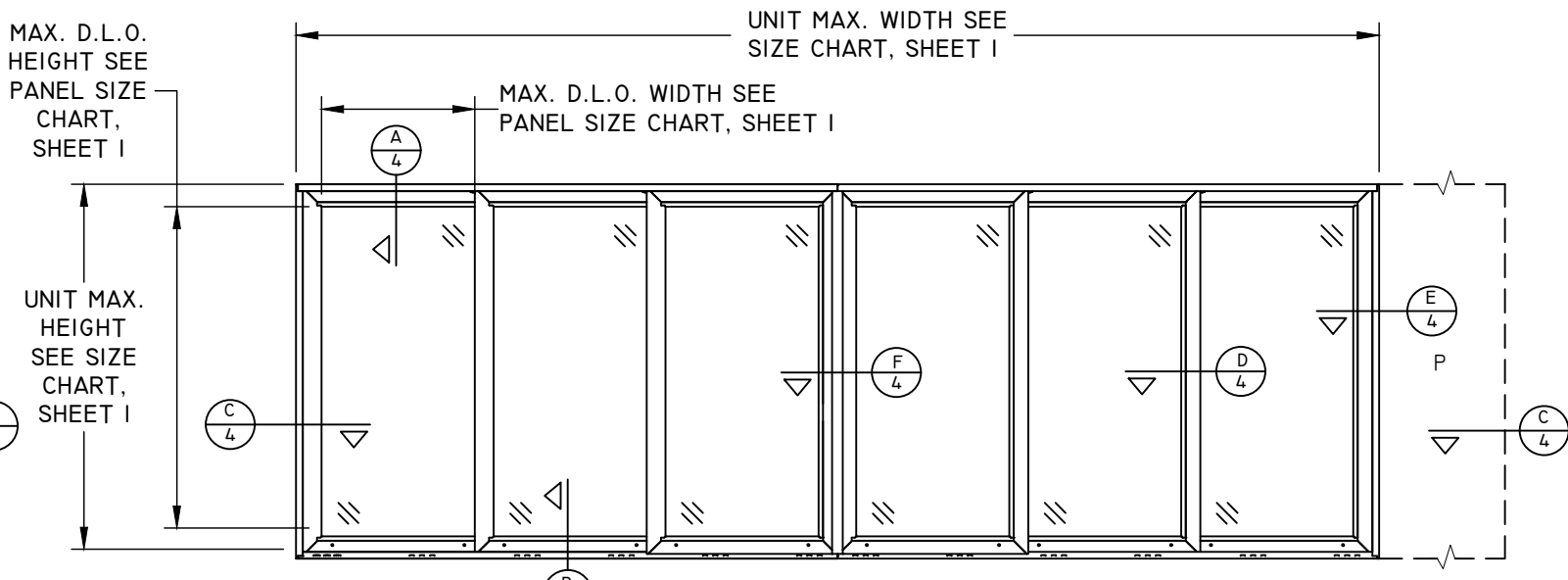

TYPICAL ELEVATION
OXX-XXO or PXXX-XXXX

2 TRACK CONFIGURATIONS		
CONFIGURATION	# OF TRACKS	# OF PANELS
XP	2	1
PX	2	1
XXP	2	2
PXX	2	2
XX	2	2
XO	2	2
OX	2	2
PX-XP	2	2
OX-O	2	3
O-XO	2	3
PXX-XXP	2	4
OX-XO	2	4

3 TRACK CONFIGURATIONS		
CONFIGURATION	# OF TRACKS	# OF PANELS
XXXXP	3	3
PXXX	3	3
XXX	3	3
XXO	3	3
OXX	3	3
PXXX-XXXXP	3	6
OXX-XXO	3	6

4 TRACK CONFIGURATIONS		
CONFIGURATION	# OF TRACKS	# OF PANELS
XXXXP	4	4
PXXXX	4	4
XXXX	4	4
XXXO	4	4
OXXX	4	4

CONFIGURATION NOTES	
CODE	PANEL TYPE
O	FIXED PANEL
X	OPERATING PANEL
P	POCKET
-	BI-PARTING

CONFIGURATION NOTES:
- ALL CONFIGURATIONS ARE AVAILABLE WITH POCKET AT EITHER OR BOTH JAMB LOCATIONS.

TITLE: PERSPECTIVE MULTI-SLIDE PD HVHZ NON-IMPACT CONFIGURATIONS & ELEVATIONS	DATE			
	BY			
	REVISION DESCRIPTION			
NO.				
DATE: 09/18/23	DWN BY: LMH	CHK BY: SAS	SCALE: NTS	



12/17/2023
LUCAS A. TURNER, P.E.
FL PE # 58201
TURNER ENGINEERING & CONSULTING, INC.
(COA # 29779)
2428 OLD NATCHEZ TRACE TRAIL, CAMDEN, TN 38320
PH. 941-380-1574

FL#: **41161**
DWG #: **PGW347**
SHEET: **3 OF 29**

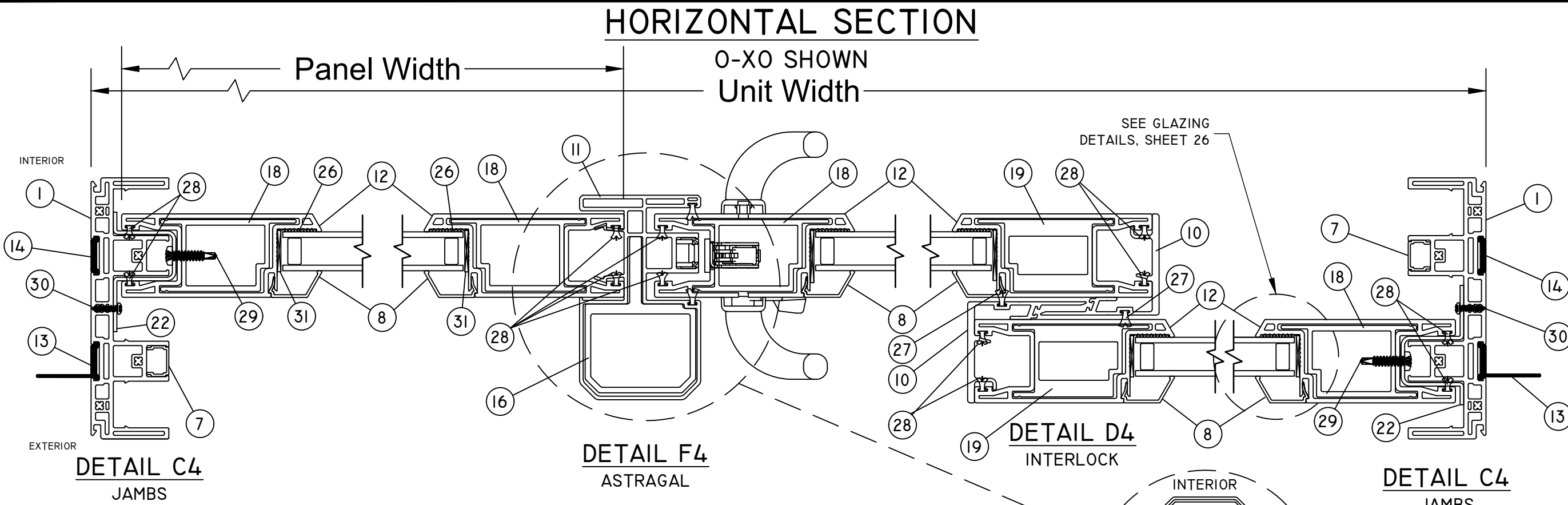

DP70 (+70/-80) HVHZ Non-IMPACT

HORIZONTAL SECTION

PXXX SHOWN

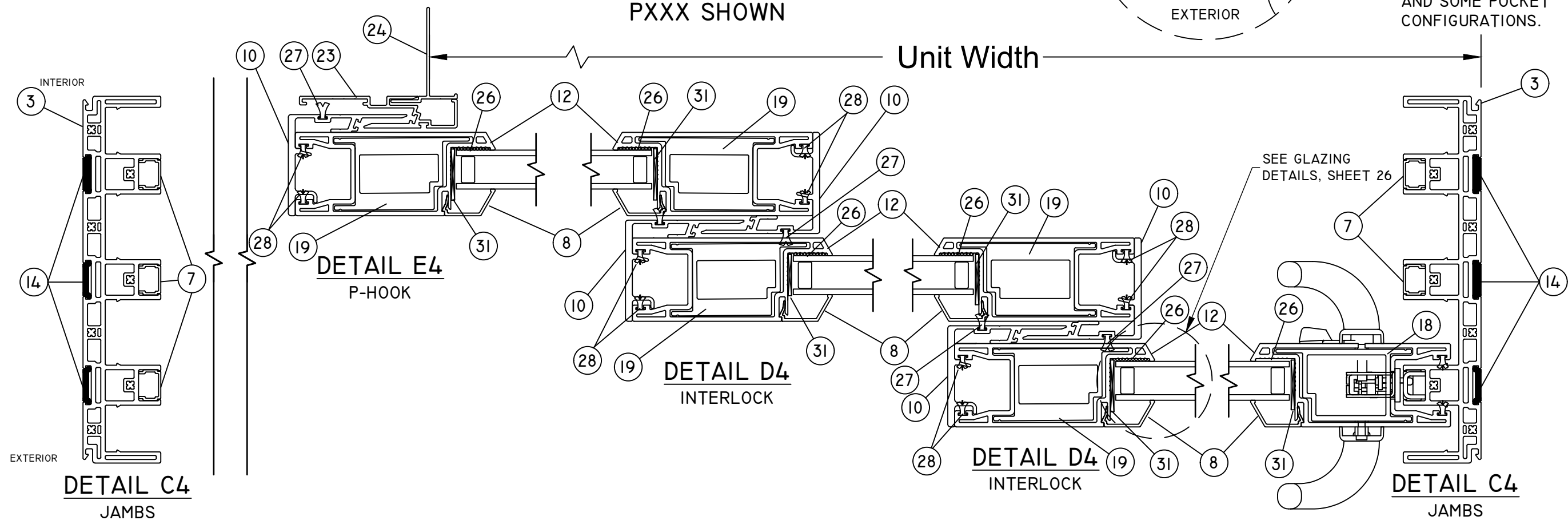

TITLE: PERSPECTIVE MULTI-SLIDE PD HVHZ Non-IMPACT HORIZONTAL SECTION DETAILS	DATE			
	BY			
	REVISION DESCRIPTION			
NO.				
DATE: 09/18/23	DWN BY: LMH	CHK BY: SAS	SCALE: NTS	

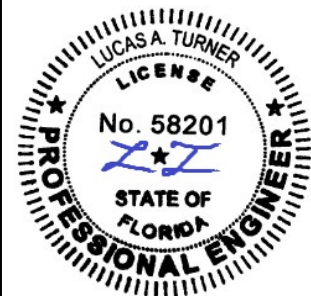

12/17/2023
LUCAS A. TURNER, P.E.
FL PE # 58201
TURNER ENGINEERING & CONSULTING, INC.
(COA # 29779)
2428 OLD NATCHEZ TRACE TRAIL, CAMDEN, TN 38320
PH. 941-380-1574

FL#: **41161**

DWG #: **PGW347**

SHEET: **4 OF 29**

DP70 (+70/-80) HVHZ NON-IMPACT

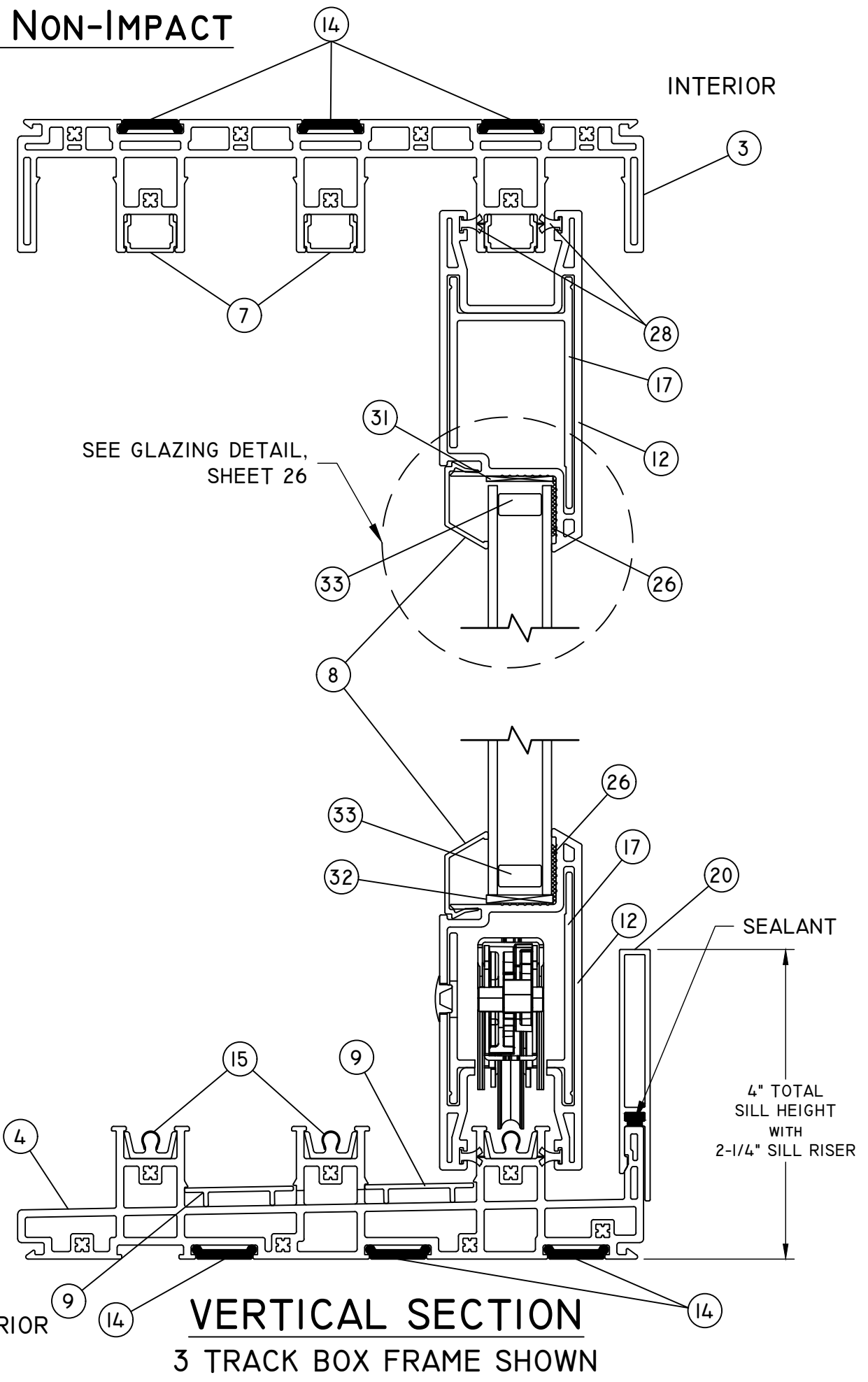
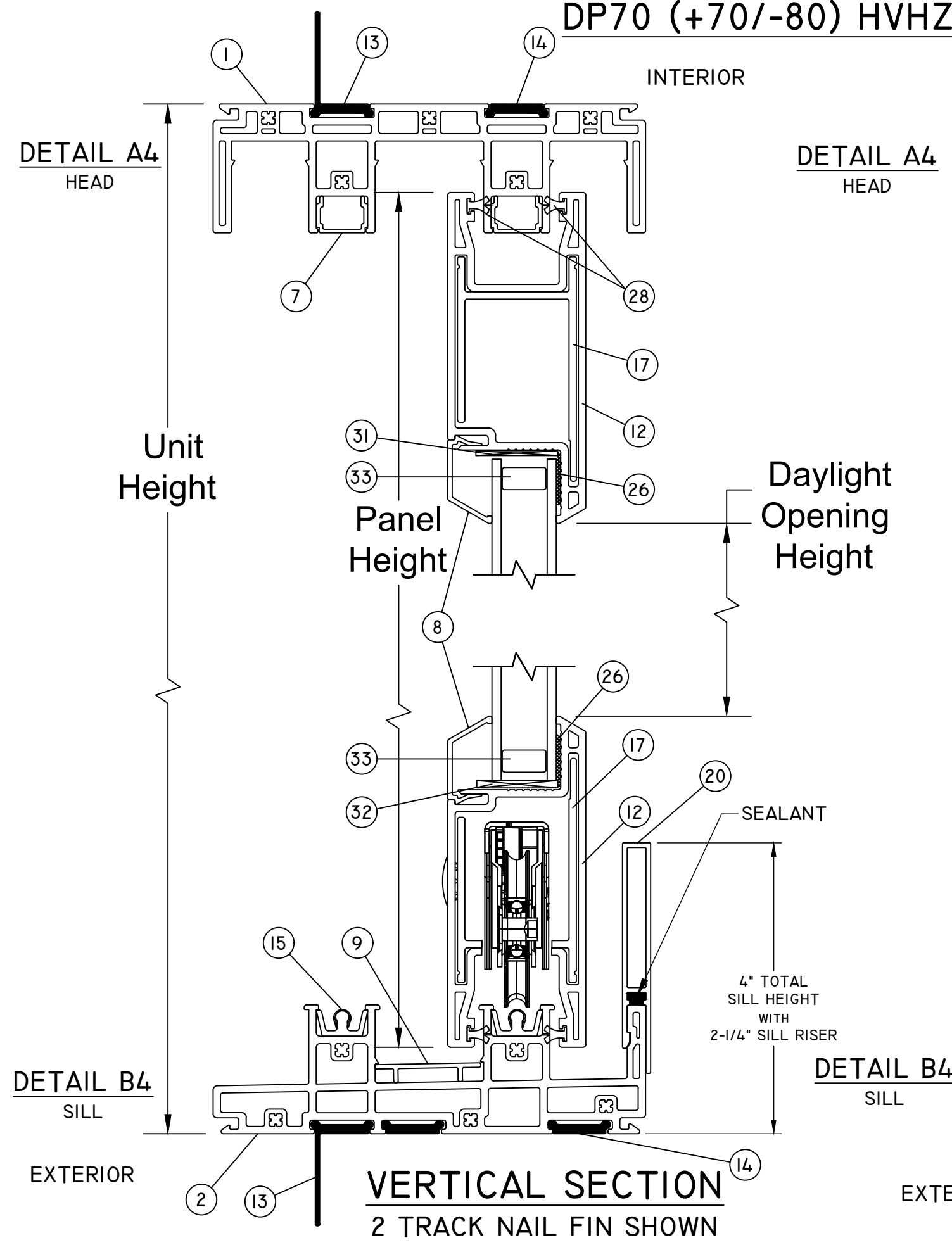

TITLE: PERSPECTIVE MULTI-SLIDE PD HVHZ NON-IMPACT VERTICAL SECTION DETAILS	DATE			
	BY			
	REVISION DESCRIPTION			
	NO.			
DATE:	DWN BY:	CHK BY:	SCALE:	
09/18/23	LMH	SAS	NTS	



12/17/2023
LUCAS A. TURNER, P.E.
FL PE # 58201
TURNER ENGINEERING & CONSULTING, INC.
(COA # 29779)
2428 OLD NATCHEZ TRACE TRAIL, CAMDEN, TN 38320
PH. 941-380-1574

FL#: **41161**

DWG #: **PGW347**

SHEET: **5 OF 29**

2 TRACK ANCHOR LAYOUT DETAILS WITH NAIL FIN - HEAD

HEAD - DP70 (+70/-80) HVHZ NON-IMPACT

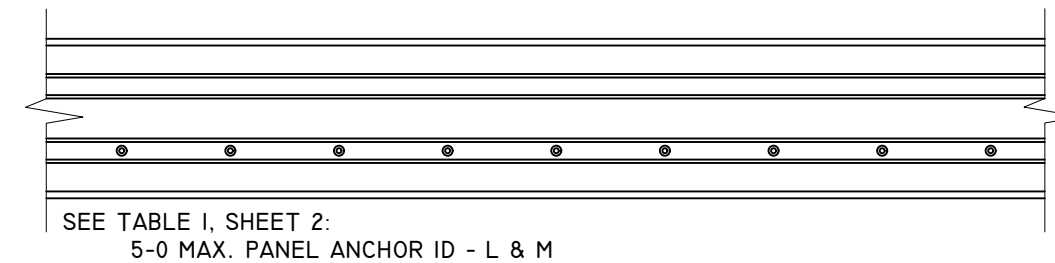
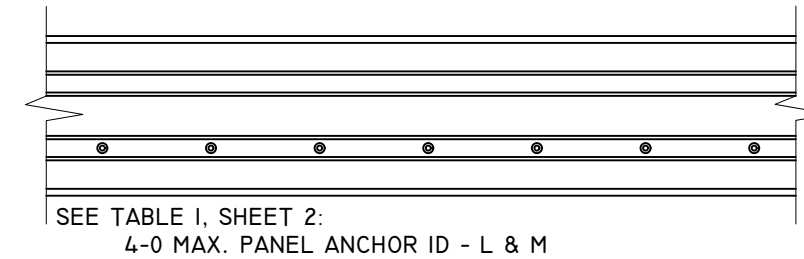
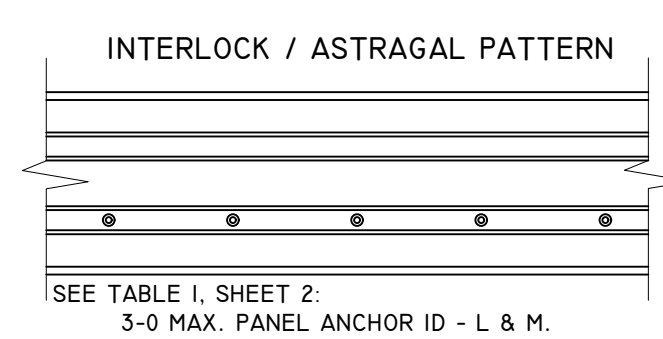
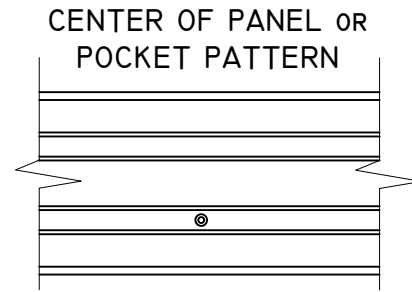
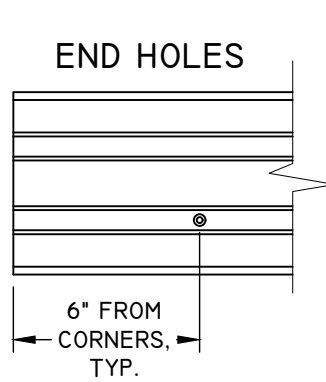
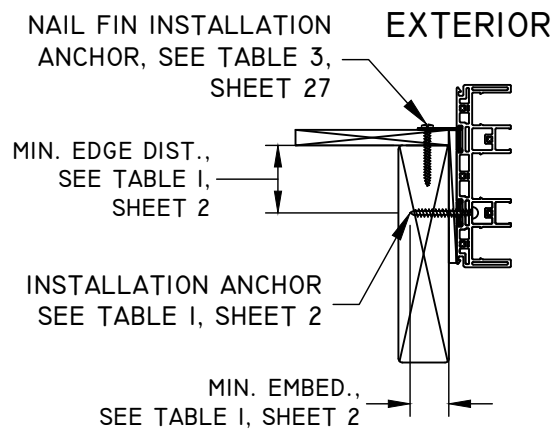

INTERIOR

TYPICAL PATTERN AT SPLICE
4" MIN. ON CENTER SPACING

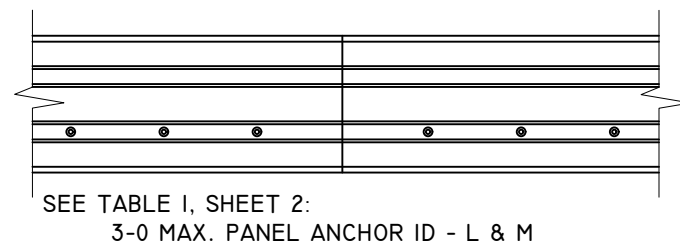
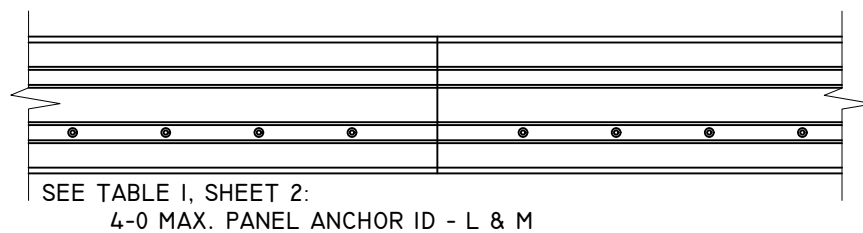
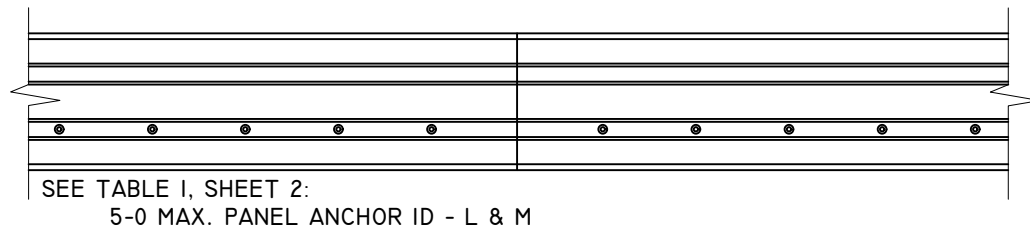

NOTES:

1. UNIT MUST BE INSTALLED WITH ANCHORS THROUGH FRAME AND THROUGH NAIL FIN SIMULTANEOUSLY.
2. 2X MIN. WOOD OR METAL INSTALLATIONS ONLY. WOOD OR METAL MAY BE INSTALLED BY OTHERS OVER CONCRETE/MASONRY NOT SHOWN.
3. SEE SHEET 27 FOR SUPPLEMENTAL INSTALLATION PATTERN THROUGH NAIL FIN, DETAIL A.
4. FRAME INSTALLATION HOLES ARE FABRICATED BY MANUFACTURER.
5. SEE TABLE 1, SHEET 2 FOR FASTENER MINIMUM EDGE DISTANCE, EMBEDMENT AND ON CENTER SPACING.
6. 1/4" MAX. SHIM STACK.
7. SPLICE DETAIL, SEE SHEET 26.

TITLE: PERSPECTIVE MULTI-SLIDE PD HVHZ NON-IMPACT ANCHOR LAYOUT	DATE				
	BY				
	REVISION DESCRIPTION				
NO.					
DATE: 09/18/23	DWN BY: LMH	CHK BY: SAS	SCALE: NTS		



12/17/2023
LUCAS A. TURNER, P.E.
FL PE # 58201
TURNER ENGINEERING & CONSULTING, INC.
(COA # 29779)
2428 OLD NATCHEZ TRACE
TRAIL, CAMDEN, TN 38320
PH. 941-380-1574

FL#: 41161

DWG #: PGW347

SHEET: 6 OF 29

2 TRACK ANCHOR LAYOUT DETAILS WITH NAIL FIN - SILL

SILL - DP70 (+70/-80) HVHZ NON-IMPACT

PlyGem
WINDOWS & DOORS
Part of the Cornerstone Building Brands Family
433 N. MAIN ST.,
PO BOX 559,
ROCKY MOUNT, VA 24151
PH: 540-484-6348
FX: 540-484-6683

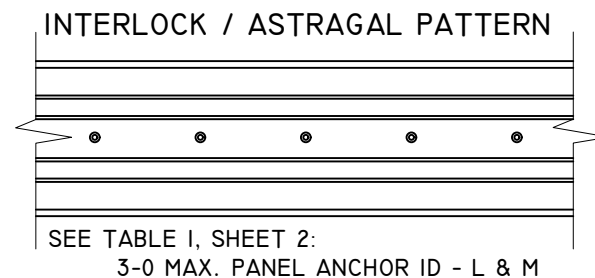
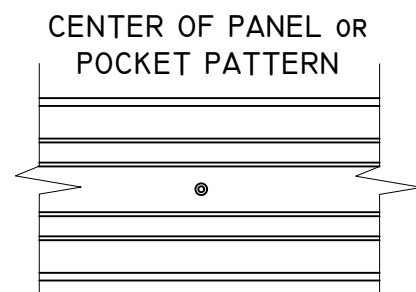
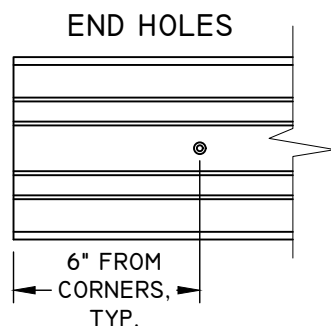

EXTERIOR

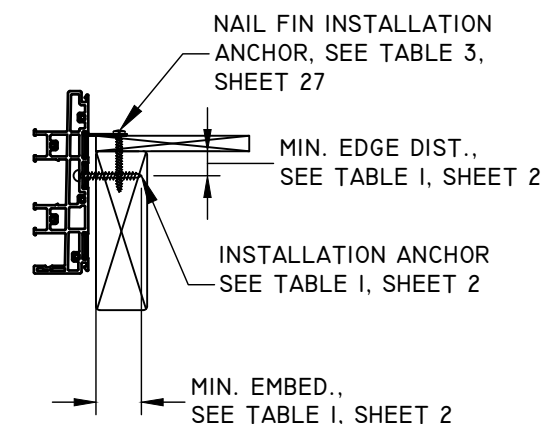

INTERIOR

TYPICAL PATTERN AT SPLICE
4" MIN. ON CENTER SPACING

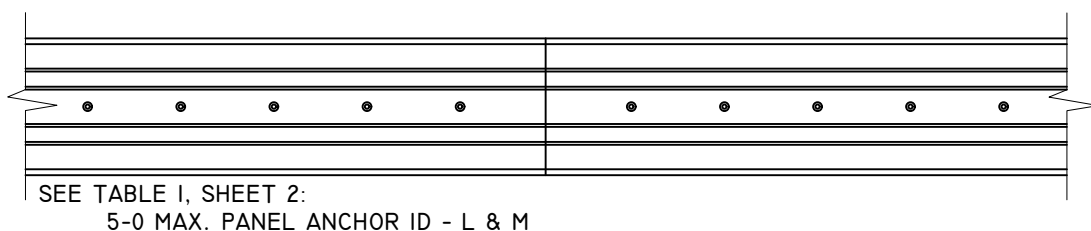
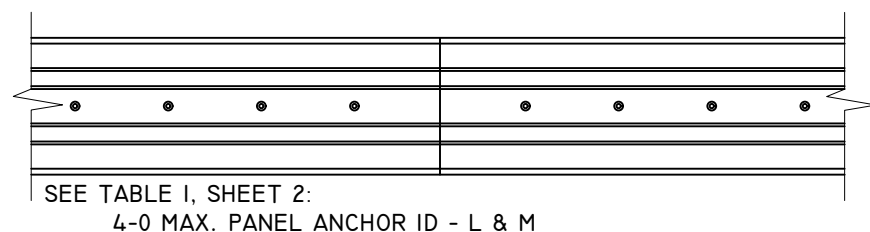
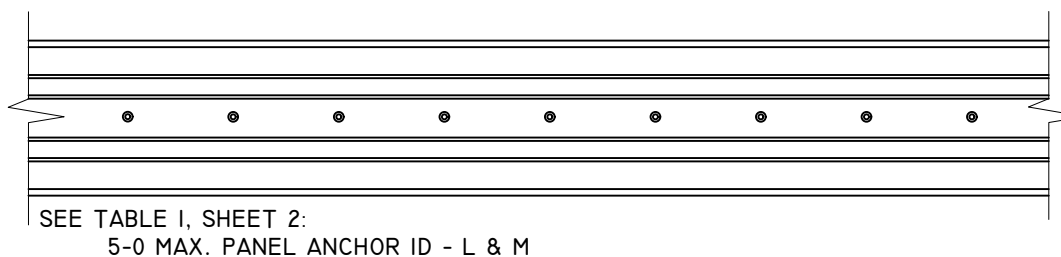
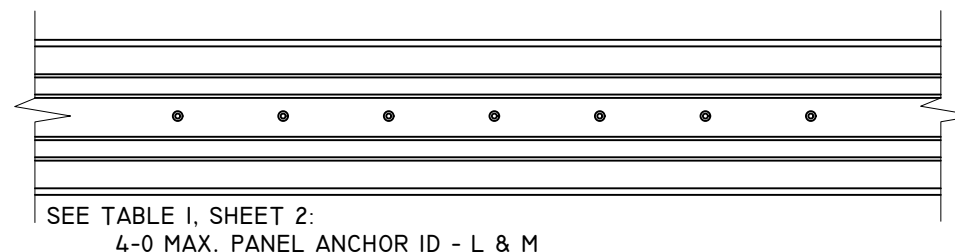
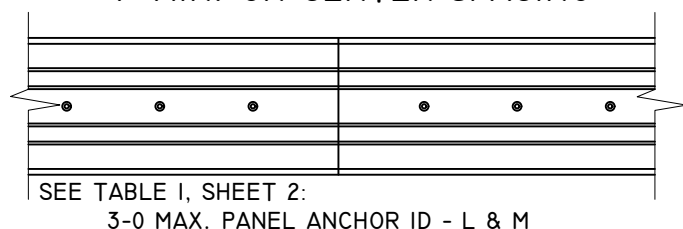

NOTES:

1. UNIT MUST BE INSTALLED WITH ANCHORS THROUGH FRAME AND THROUGH NAIL FIN SIMULTANEOUSLY.
2. 2X MIN. WOOD OR METAL INSTALLATIONS ONLY. WOOD OR METAL MAY BE INSTALLED BY OTHERS OVER CONCRETE/MASONRY, NOT SHOWN.
3. SEE SHEET 27 FOR SUPPLEMENTAL INSTALLATION PATTERN THROUGH NAIL FIN, DETAIL B - ALTERNATE.
4. FRAME INSTALLATION HOLES ARE FABRICATED BY MANUFACTURER.
5. SEE TABLE I, SHEET 2 FOR FASTENER MINIMUM EDGE DISTANCE, EMBEDMENT AND ON CENTER SPACING.
6. 1/4" MAX. SHIM STACK.
7. SPLICE DETAIL, SEE SHEET 26.
8. FILL ALL PRE-DRILLED INSTALLATION HOLES WITH EXTERIOR GRADE SEALANT PRIOR TO INSERTING SCREWS AND APPLY SEALANT OVER THE HEAD OF SCREWS ONCE PROPERLY SEATED.

TITLE: PERSPECTIVE MULTI-SLIDE PD HVHZ NON-IMPACT ANCHOR LAYOUT	DATE			
	BY			
NO.	REVISION DESCRIPTION			
DATE: 09/18/23	DWN BY: LMH	CHK BY: SAS	SCALE: NTS	

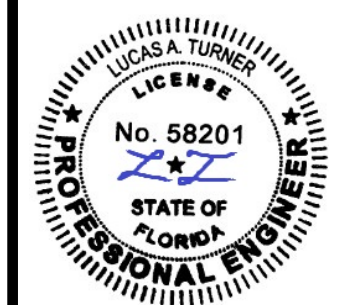

12/17/2023
LUCAS A. TURNER, P.E.
FL PE # 58201
TURNER ENGINEERING & CONSULTING, INC.
(COA # 29779)
2428 OLD NATCHEZ TRACE TRAIL, CAMDEN, TN 38320
PH. 941-380-1574

FL#: 41161

DWG #: PGW347

SHEET: 7 OF 29

2 TRACK ANCHOR LAYOUT DETAILS WITH NAIL FIN - JAMBS

JAMB - DP70 (+70/-80) HVHZ Non-IMPACT

SEE TABLE I, SHEET 2:
ANCHOR ID - L & M

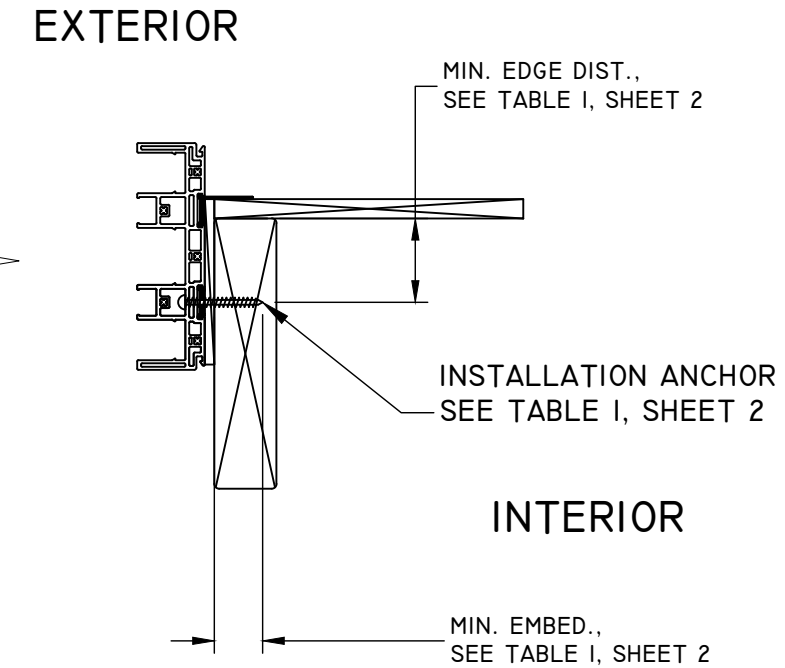
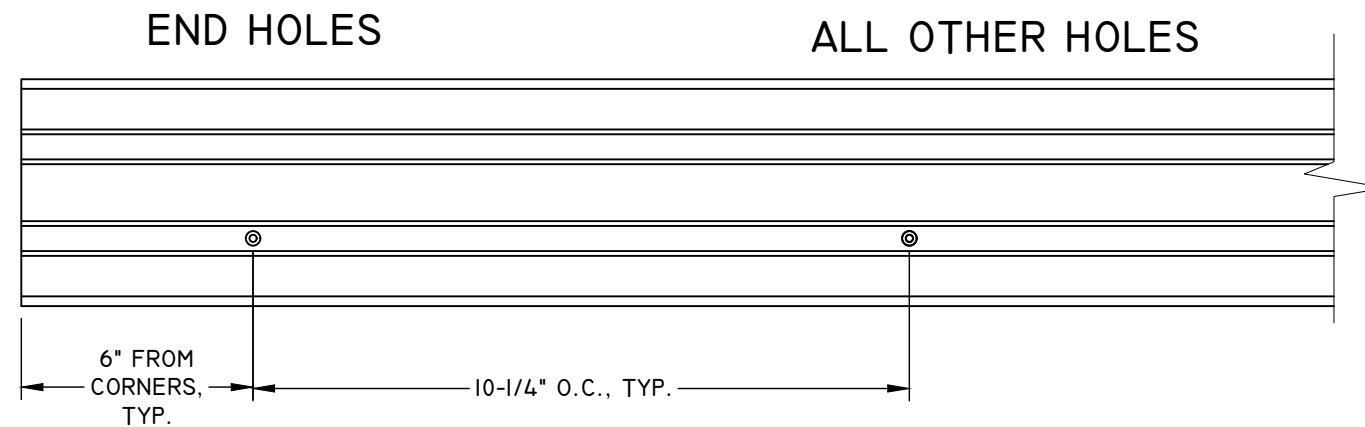

NOTES:

1. INSTALLATION HOLES ARE FABRICATED BY MANUFACTURER.
2. SEE TABLE I, SHEET 2 FOR FASTENER MINIMUM EDGE DISTANCE, EMBEDMENT AND ON CENTER SPACING.
2. 2X MIN. WOOD OR METAL INSTALLATIONS ONLY. WOOD OR METAL MAY BE INSTALLED BY OTHERS OVER CONCRETE/MASONRY NOT SHOWN.
3. 1/4" MAX. SHIM STACK.
4. FILL LEFT & RIGHT PRE-DRILLED JAMB INSTALLATION HOLES - 6" FROM CORNER OF SILL ONLY, WITH EXTERIOR GRADE SEALANT PRIOR TO INSERTING SCREWS AND APPLY SEALANT OVER THE HEAD OF THE SCREWS ONCE PROPERLY SEATED.

TITLE: PERSPECTIVE MULTI-SLIDE PD HVHZ Non-IMPACT ANCHOR LAYOUT	DATE				
	BY				
	REVISION DESCRIPTION				
	NO.				
DATE:	09/18/23	DWN BY:	LMH	CHK BY:	SAS
				SCALE:	NTS

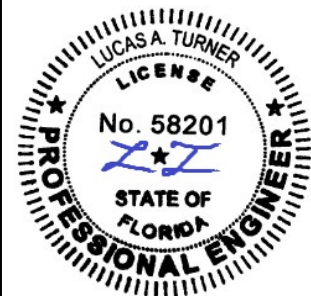

12/17/2023
LUCAS A. TURNER, P.E.
FL PE # 58201
TURNER ENGINEERING & CONSULTING, INC.
(COA # 29779)
2428 OLD NATCHEZ TRACE
TRAIL, CAMDEN, TN 38320
PH. 941-380-1574

FL#:	41161
DWG #:	PGW347
SHEET:	8 OF 29

2 TRACK ANCHOR LAYOUT DETAILS BOX FRAME - HEAD

HEAD - DP70 (+70/-80) IMPACT HVHZ NON-IMPACT

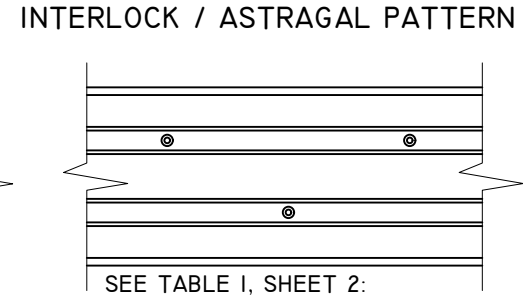
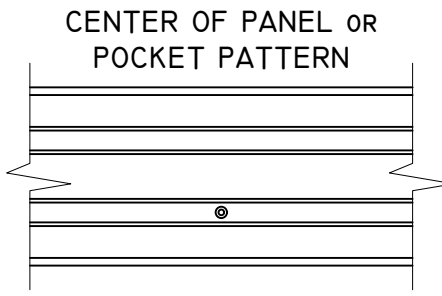
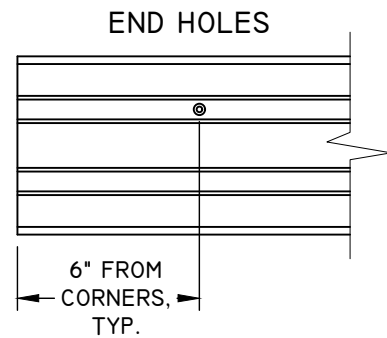
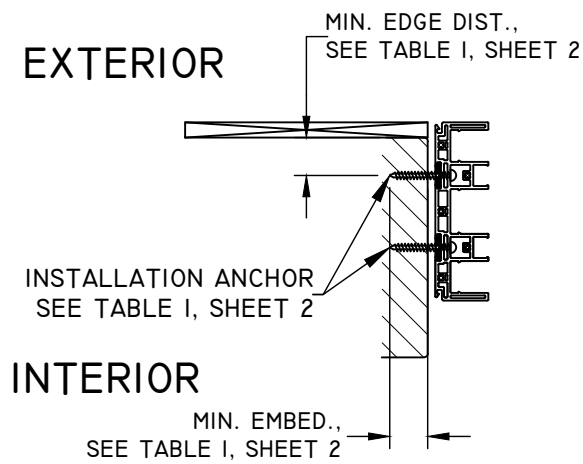

TYPICAL PATTERN AT SPLICE
4" MIN. ON CENTER SPACING

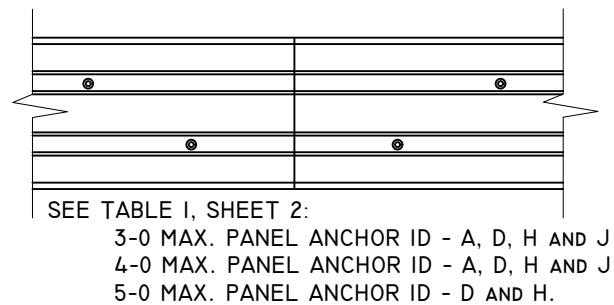
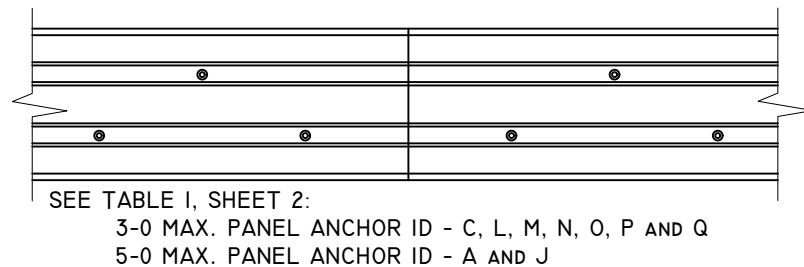
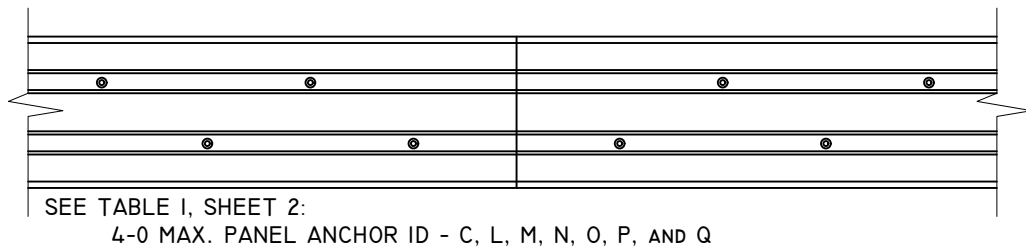
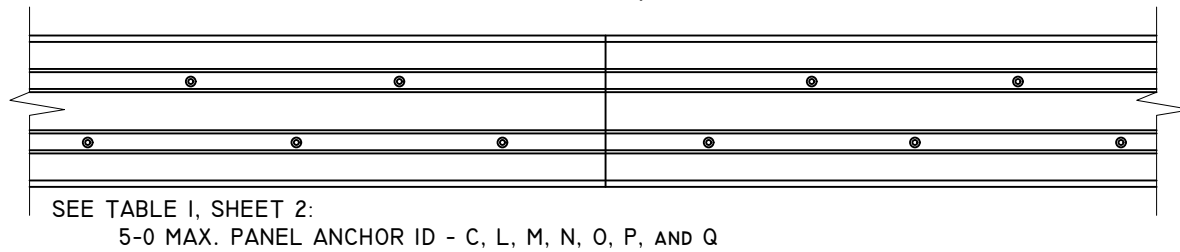

SEE TABLE I, SHEET 2:
3-0 MAX. PANEL ANCHOR ID - A, D, H AND J
4-0 MAX. PANEL ANCHOR ID - D AND H
5-0 MAX. PANEL ANCHOR ID - D

SEE TABLE I, SHEET 2:
4-0 MAX. PANEL ANCHOR ID - A AND J
5-0 MAX. PANEL ANCHOR ID - H*

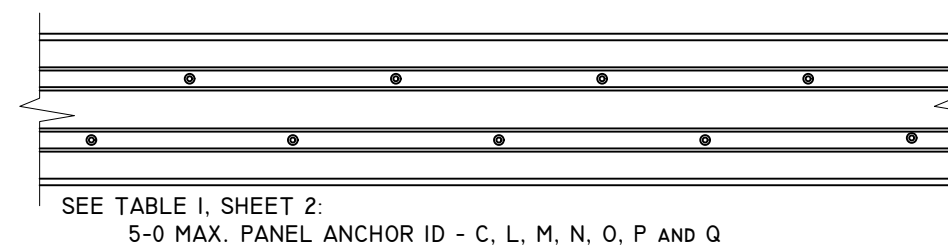
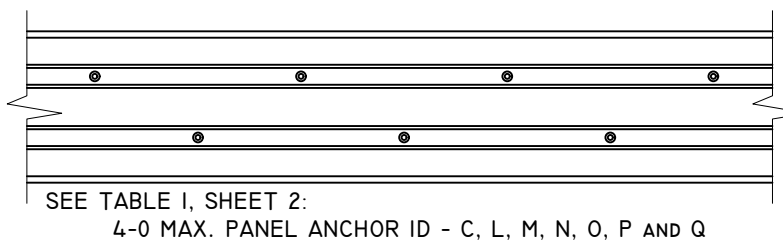
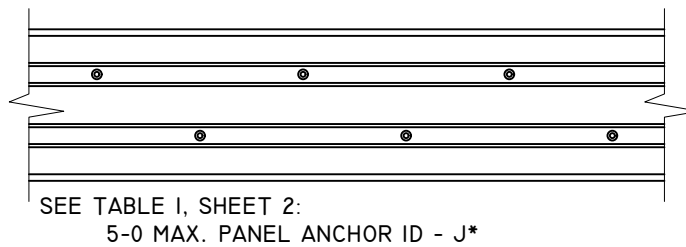
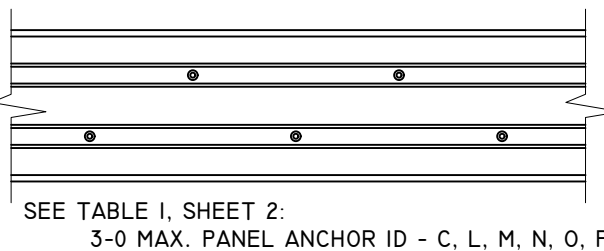

NOTES:

1. INTERLOCK/ASTRAGAL INSTALLATION HOLES ARE FABRICATED BY MANUFACTURER. EXCEPTION: ANCHORS H & J.
 - 1.1. ANCHOR H*: 5-0 PANELS REQUIRE 4 ANCHOR PER CLUSTER, 3 INSTALLATION HOLES ARE PRE-DRILLED BY MANUFACTURER.
2. SEE TABLE I, SHEET 2 FOR FASTENER MINIMUM EDGE DISTANCE, EMBEDMENT AND ON CENTER SPACING.
3. IX WOOD BUCK BY OTHERS IS OPTIONAL FOR MASONRY APPLICATIONS.
4. 1/4" MAX. SHIM STACK.
5. SPLICE DETAIL, SEE SHEET 26.

TITLE: PERSPECTIVE MULTI-SLIDE PD HVHZ NON-IMPACT ANCHOR LAYOUT	DATE			
	BY			
	REVISION DESCRIPTION			
NO.				
DATE: 09/18/23	DWN BY: LMH	CHK BY: SAS	SCALE: NTS	

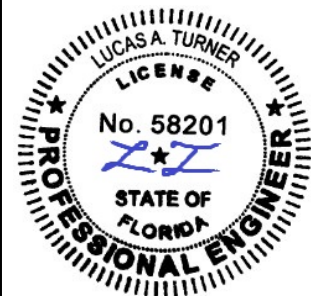

12/17/2023
LUCAS A. TURNER, P.E.
FL PE # 58201
TURNER ENGINEERING &
CONSULTING, INC.
(COA # 29779)
2428 OLD NATCHEZ TRACE
TRAIL, CAMDEN, TN 38320
PH. 941-380-1574

FL#: 41161
DWG #: PGW347
SHEET: 9 OF 29

2 TRACK ANCHOR LAYOUT DETAILS BOX FRAME - SILL

SILL - DP70 (+70/-80) IMPACT HVHZ NON-IMPACT

NOTES:

1. INTERLOCK/ASTRAGAL INSTALLATION HOLES ARE FABRICATED BY MANUFACTURER. EXCEPTION: ANCHORS H & J.

1.1. ANCHOR H*: 5-0 PANELS REQUIRE 4 ANCHOR PER CLUSTER, 3 INSTALLATION HOLES ARE PRE-DRILLED BY MANUFACTURER.

2. SEE TABLE I, SHEET 2 FOR FASTENER MINIMUM EDGE DISTANCE, EMBEDMENT AND ON CENTER SPACING.

3. IX WOOD BUCK BY OTHERS IS OPTIONAL FOR MASONRY APPLICATIONS.

4. SILL NAIL FIN IS OPTIONAL.

5. 1/4" MAX. SHIM STACK.

6. SPLICE DETAIL, SEE SHEET 26.

7. FILL ALL PRE-DRILLED INSTALLATION HOLES WITH EXTERIOR GRADE SEALANT PRIOR TO INSERTING SCREWS AND APPLY SEALANT OVER THE HEAD OF SCREWS ONCE PROPERLY SEATED.

END HOLES

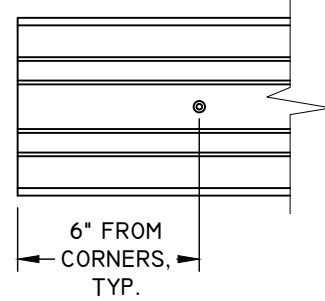

CENTER OF PANEL OR POCKET PATTERN

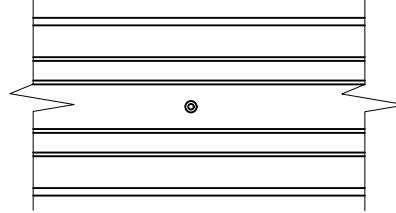

INTERLOCK / ASTRAGAL PATTERN

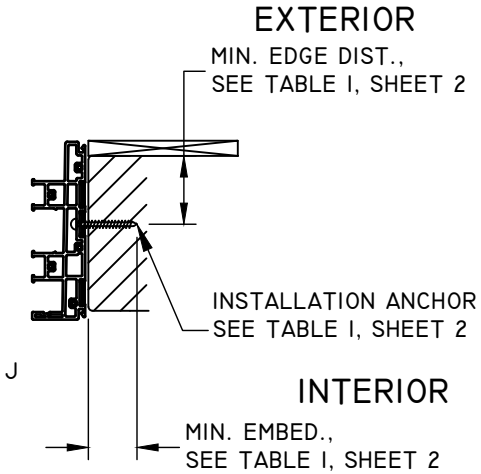
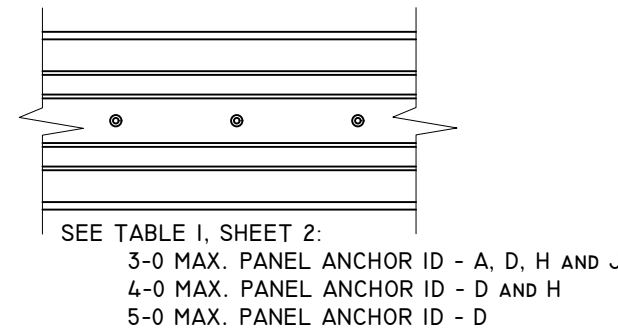

TYPICAL PATTERN AT SPLICE
4" MIN. ON CENTER SPACING

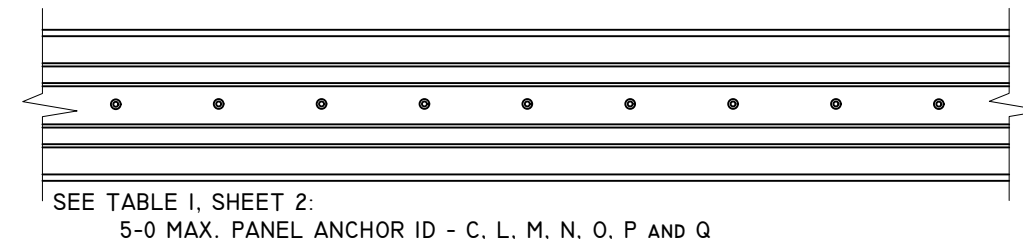
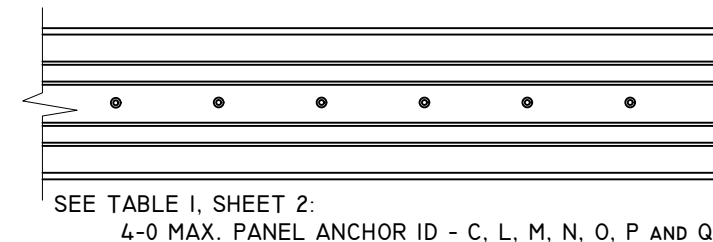
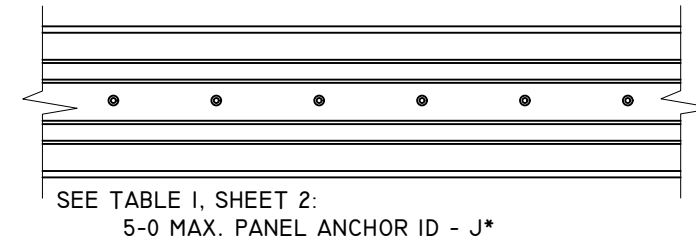
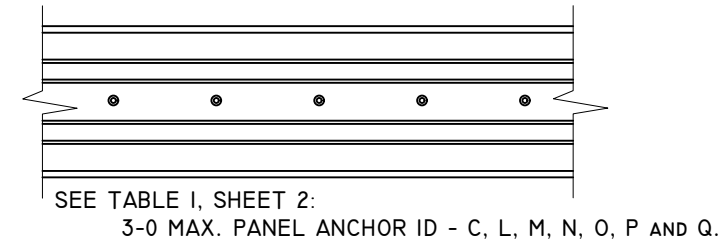
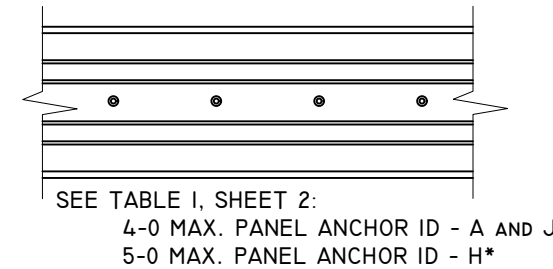
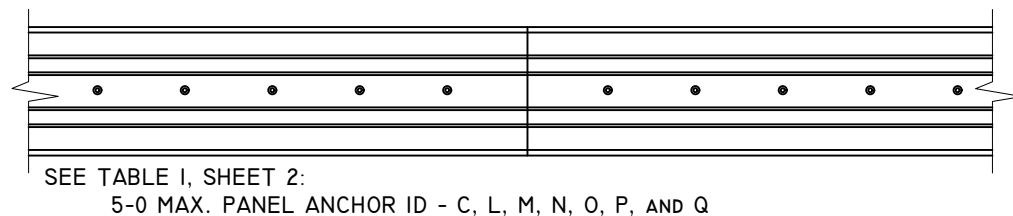
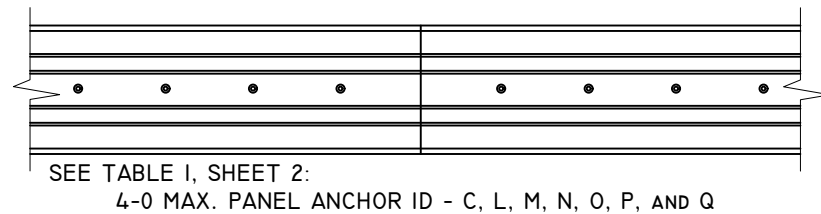
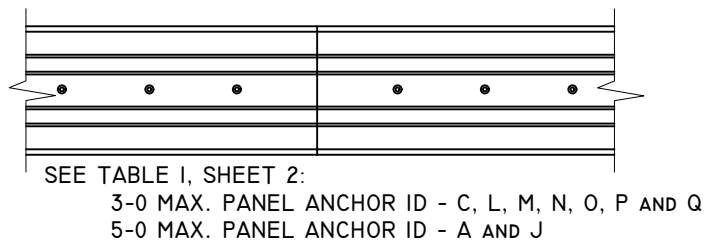
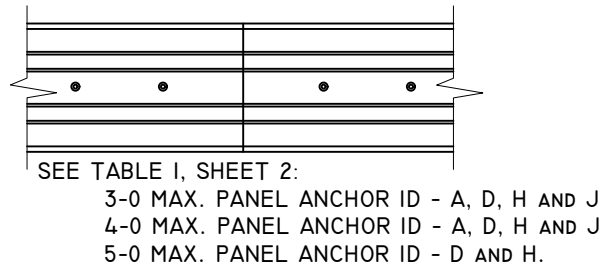

Ply Gem
WINDOWS & DOORS
Part of the Cornerstone Building Brands Family
433 N. MAIN ST.,
PO BOX 559,
ROCKY MOUNT, VA 24151
PH: 540-484-6348
FX: 540-484-6683

TITLE: PERSPECTIVE MULTI-SLIDE PD HVHZ NON-IMPACT ANCHOR LAYOUT	DATE			
	DWN BY:	LMH	CHK BY:	SAS
NO.				
REVISION DESCRIPTION				
BY				
DATE				

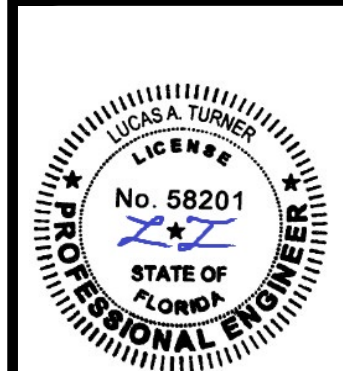

12/17/2023
LUCAS A. TURNER, P.E.
FL PE # 58201
TURNER ENGINEERING & CONSULTING, INC.
(COA # 29779)
2428 OLD NATCHEZ TRACE
TRAIL, CAMDEN, TN 38320
PH. 941-380-1574

FL#: 41161
DWG #: PGW347
SHEET: 10 OF 29

2 TRACK ANCHOR LAYOUT DETAILS BOX FRAME - JAMBS

JAMB - DP70 (+70/-80) HVHZ NON-IMPACT

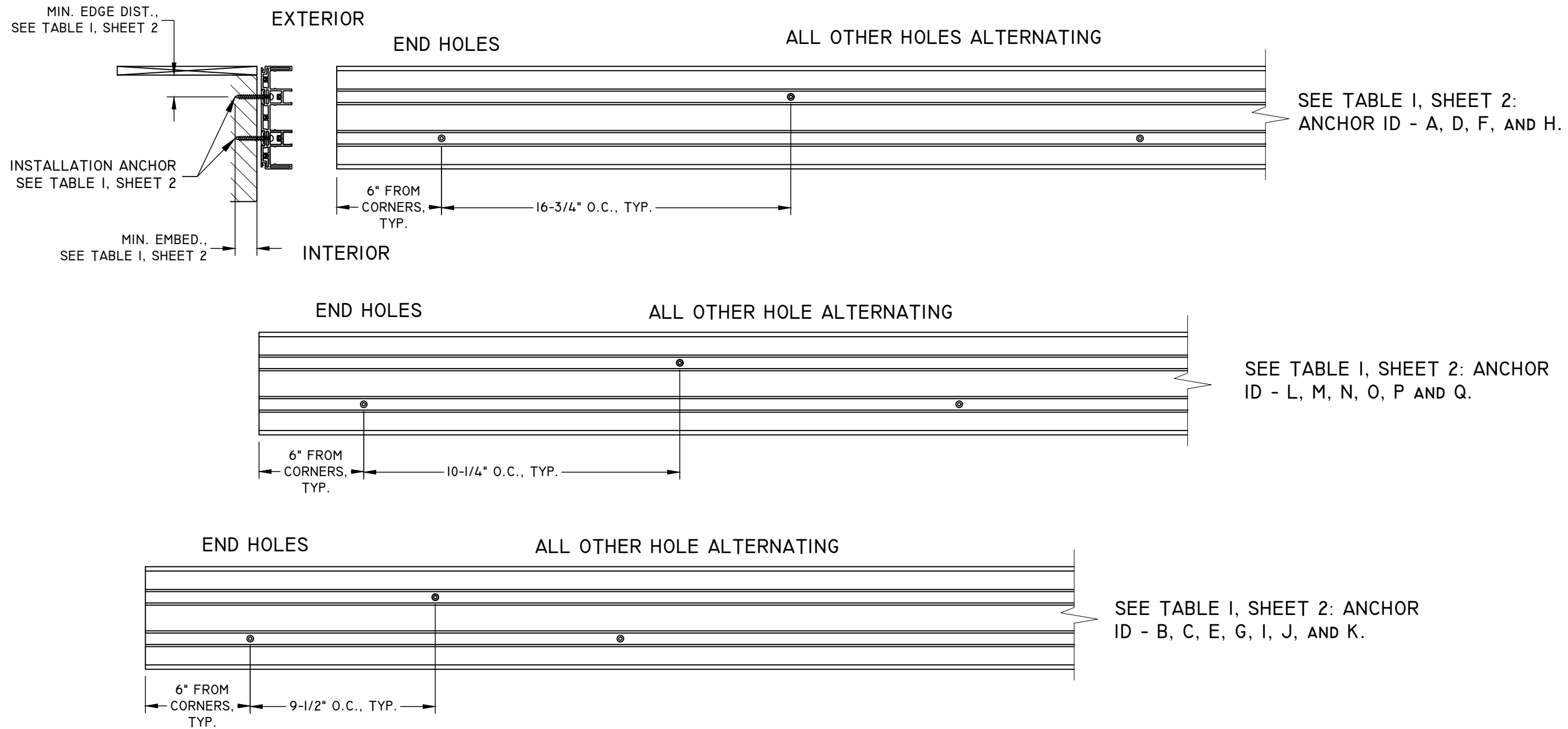

NOTES:

1. INSTALLATION HOLES ARE FABRICATED BY MANUFACTURER.
2. SEE TABLE I, SHEET 2 FOR FASTENER MINIMUM EDGE DISTANCE, EMBEDMENT AND ON CENTER SPACING.
3. IX WOOD BUCK BY OTHERS IS OPTIONAL FOR MASONRY APPLICATIONS.
4. 1/4" MAX. SHIM STACK.
5. FILL LEFT & RIGHT PRE-DRILLED JAMB INSTALLATION HOLES - 6" FROM CORNER OF SILL ONLY, WITH EXTERIOR GRADE SEALANT PRIOR TO INSERTING SCREWS AND APPLY SEALANT OVER THE HEAD OF THE SCREWS ONCE PROPERLY SEATED.

TITLE: PERSPECTIVE MULTI-SLIDE PD HVHZ NON-IMPACT ANCHOR LAYOUT	DATE			
	BY			
NO.	REVISION DESCRIPTION			
DATE: 09/18/23	DWN BY: LMH	CHK BY: SAS	SCALE: NTS	

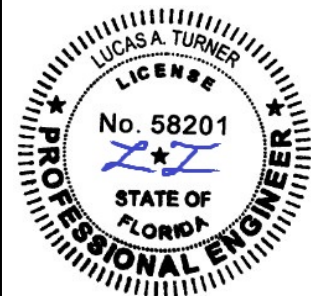

12/17/2023
LUCAS A. TURNER, P.E.
FL PE # 58201
TURNER ENGINEERING & CONSULTING, INC.
(COA # 29779)
2428 OLD NATCHEZ TRACE
TRAIL, CAMDEN, TN 38320
PH. 941-380-1574

FL#:	41161
DWG #:	PGW347
SHEET:	11 OF 29

3 TRACK ANCHOR LAYOUT DETAILS WITH NAIL FIN - HEAD

HEAD - DP70 (+70/-80) HVHZ Non-IMPACT

Ply Gem
WINDOWS & DOORS
Part of the Cornerstone Building Brands Family
433 N. MAIN ST.,
PO BOX 559,
ROCKY MOUNT, VA 24151
PH: 540-484-6348
FX: 540-484-6683

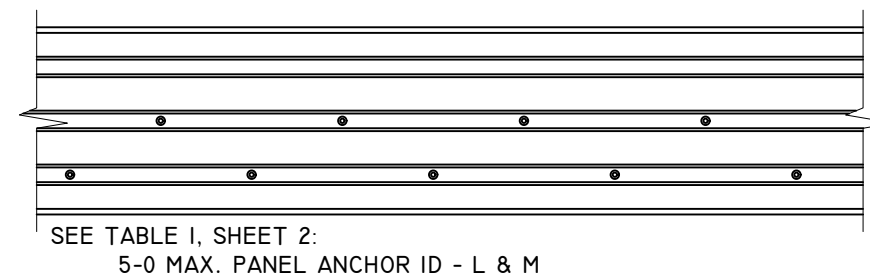
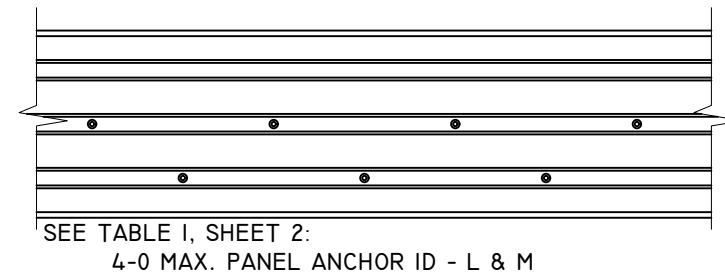
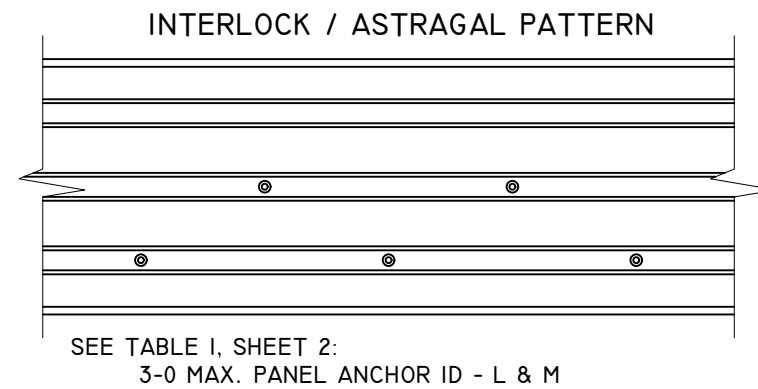
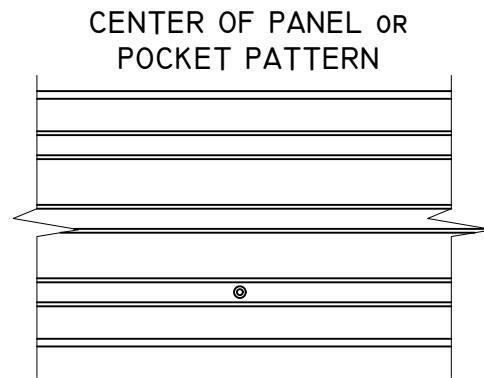
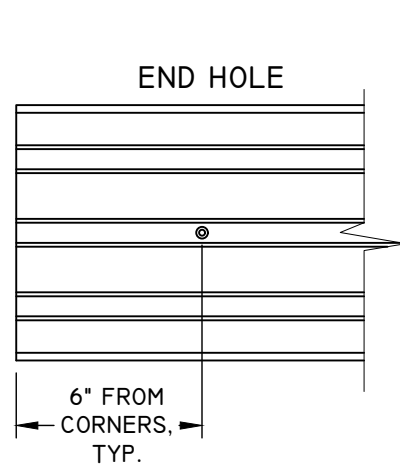
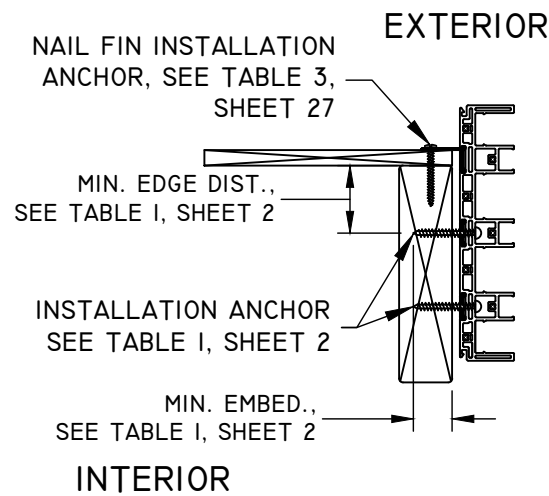

TYPICAL PATTERN AT SPLICE
4" MIN. ON CENTER SPACING

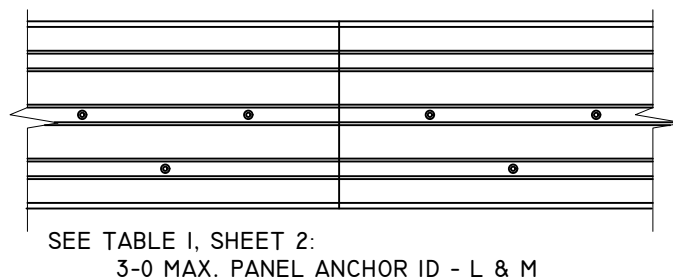
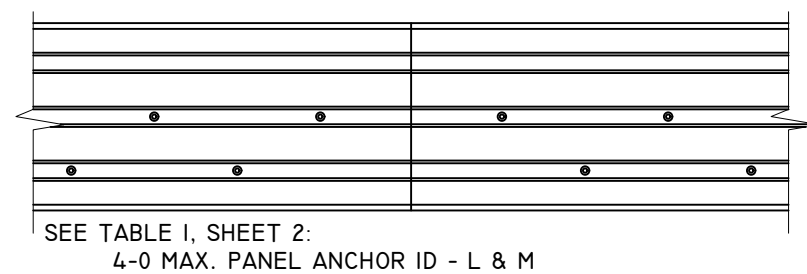
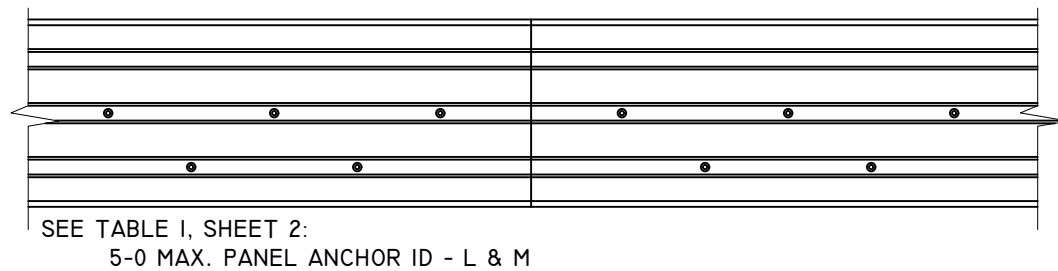

NOTES:

1. UNIT MUST BE INSTALLED WITH ANCHORS THROUGH FRAME AND THROUGH NAIL FIN SIMULTANEOUSLY.
2. 2X MIN. WOOD OR METAL INSTALLATIONS ONLY. WOOD OR METAL MAY BE INSTALLED BY OTHERS OVER CONCRETE/MASONRY NOT SHOWN.
3. SEE SHEET 27 FOR SUPPLEMENTAL INSTALLATION PATTERN THROUGH NAIL FIN, DETAIL A.
4. FRAME INSTALLATION HOLES ARE FABRICATED BY MANUFACTURER.
5. SEE TABLE I, SHEET 2 FOR FASTENER MINIMUM EDGE DISTANCE, EMBEDMENT AND ON CENTER SPACING.
6. 1/4" MAX. SHIM STACK.
7. SPLICE DETAIL, SEE SHEET 26.

NO.	REVISION DESCRIPTION	BY	DATE

TITLE: PERSPECTIVE MULTI-SLIDE PD HVHZ Non-IMPACT ANCHOR LAYOUT

DATE:	DWN BY:	CHK BY:	SCALE:
09/18/23	LMH	SAS	NTS



12/17/2023
LUCAS A. TURNER, P.E.
FL PE # 58201
TURNER ENGINEERING &
CONSULTING, INC.
(COA # 29779)
2428 OLD NATCHEZ TRACE
TRAIL, CAMDEN, TN 38320
PH. 941-380-1574

FL#: 41161

DWG #: PGW347

SHEET: 12 OF 29

3 TRACK ANCHOR LAYOUT DETAILS WITH NAIL FIN - SILL

SILL - DP70 (+70/-80) HVHZ NON-IMPACT

END HOLES

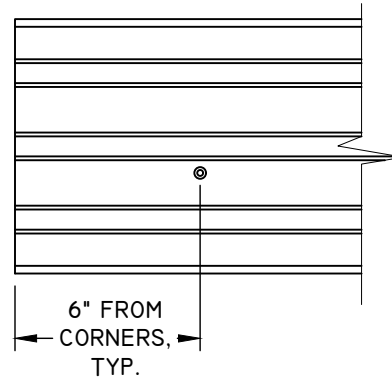

CENTER OF PANEL OR POCKET PATTERN

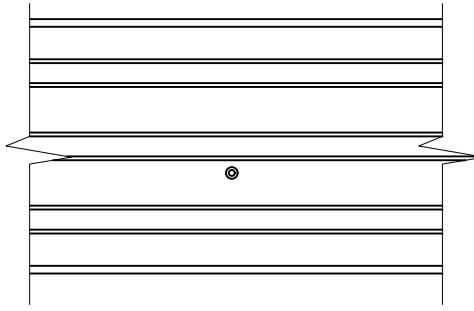

INTERLOCK / ASTRAGAL PATTERN

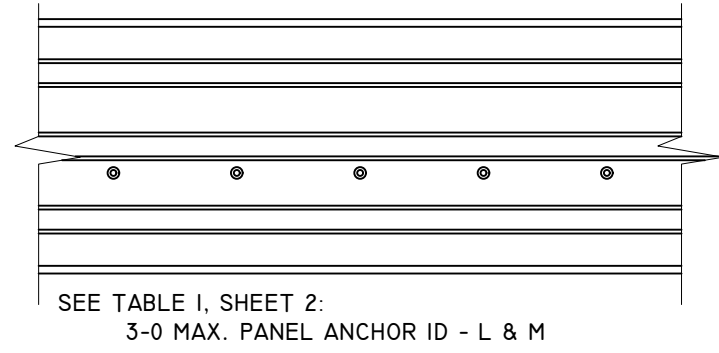

EXTERIOR

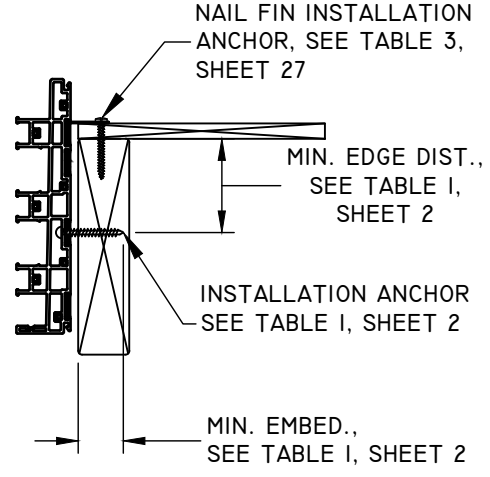

INTERIOR

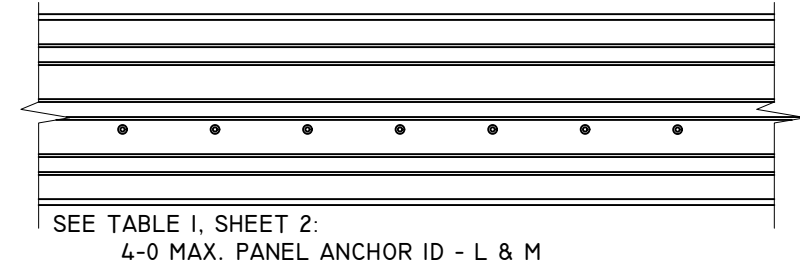

TYPICAL PATTERN AT SPLICE
4" MIN. ON CENTER SPACING

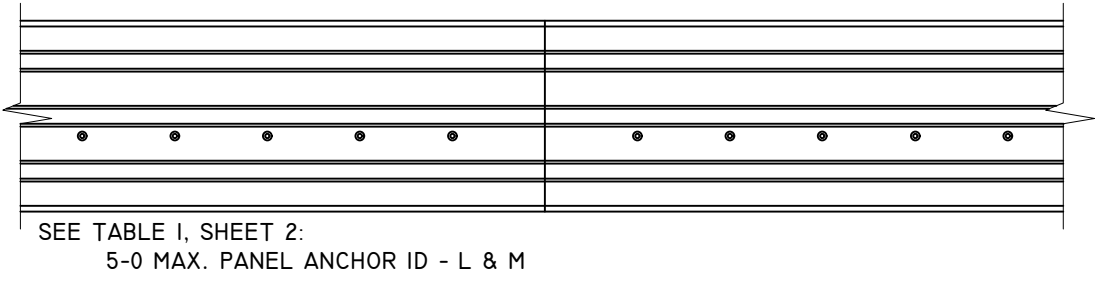
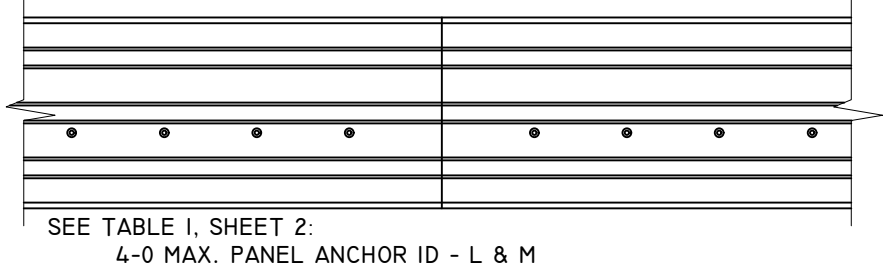
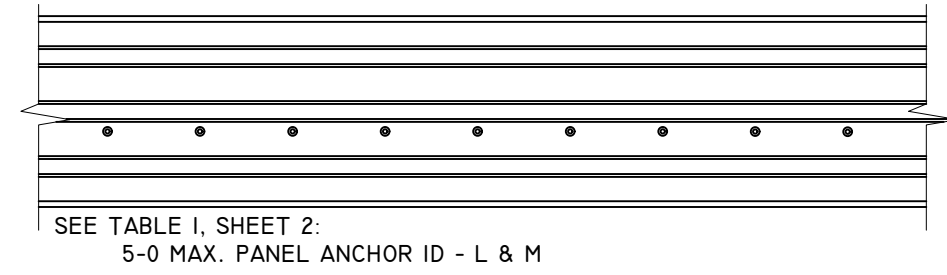
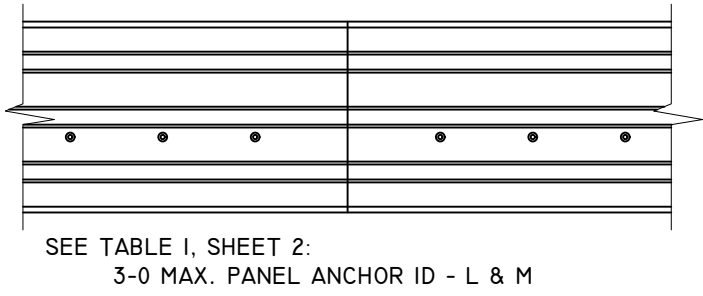

NOTES:

1. UNIT MUST BE INSTALLED WITH ANCHORS THROUGH FRAME AND THROUGH NAIL FIN SIMULTANEOUSLY.
2. 2X MIN. WOOD OR METAL INSTALLATIONS ONLY. WOOD OR METAL MAY BE INSTALLED BY OTHERS OVER CONCRETE/MASONRY, NOT SHOWN.
3. SEE SHEET 27 FOR SUPPLEMENTAL INSTALLATION PATTERN THROUGH NAIL FIN, DETAIL B - ALTERNATE.
4. FRAME INSTALLATION HOLES ARE FABRICATED BY MANUFACTURER.
5. SEE TABLE I, SHEET 2 FOR FASTENER MINIMUM EDGE DISTANCE, EMBEDMENT AND ON CENTER SPACING.
6. 1/4" MAX. SHIM STACK.
7. SPLICE DETAIL, SEE SHEET 26.
8. FILL ALL PRE-DRILLED INSTALLATION HOLES WITH EXTERIOR GRADE SEALANT PRIOR TO INSERTING SCREWS AND APPLY SEALANT OVER THE HEAD OF SCREWS ONCE PROPERLY SEATED.

TITLE: PERSPECTIVE MULTI-SLIDE PD HVHZ NON-IMPACT ANCHOR LAYOUT	DATE			
	BY			
NO.	REVISION DESCRIPTION			
DATE: 09/18/23	DWN BY: LMH	CHK BY: SAS	SCALE: NTS	



12/17/2023
LUCAS A. TURNER, P.E.
FL PE # 58201
TURNER ENGINEERING & CONSULTING, INC.
(COA # 29779)
2428 OLD NATCHEZ TRACE
TRAIL, CAMDEN, TN 38320
PH. 941-380-1574

FL#: 41161
DWG #: PGW347
SHEET: 13 OF 29

3 TRACK ANCHOR LAYOUT DETAILS WITH NAIL FIN - JAMBS

JAMB - DP70 (+70/-80) HVHZ NON-IMPACT

SEE TABLE I, SHEET 2:
ANCHOR ID - L & M.

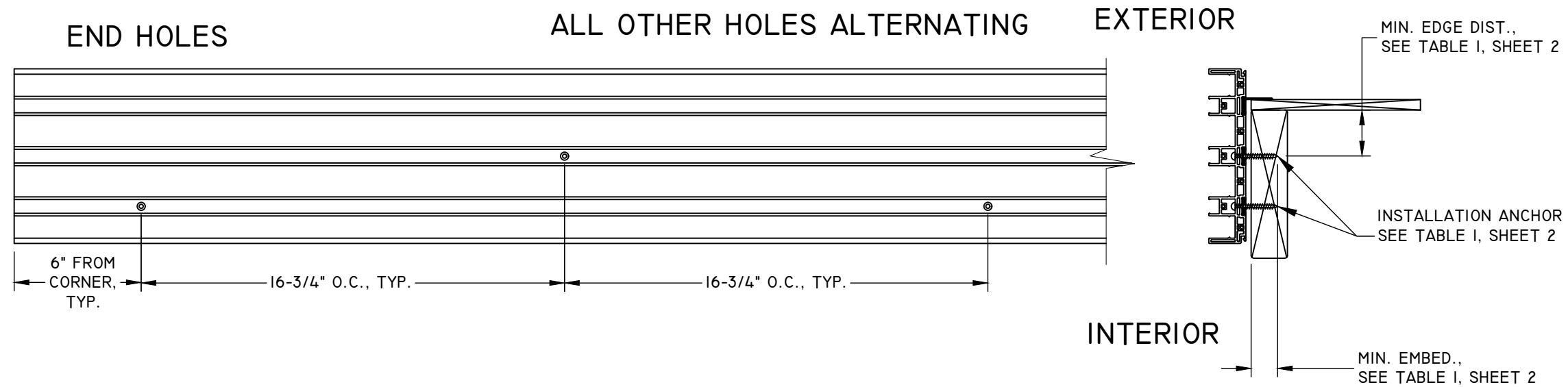

NOTES:

1. INSTALLATION HOLES ARE FABRICATED BY MANUFACTURER.
2. SEE TABLE I, SHEET 2 FOR FASTENER MINIMUM EDGE DISTANCE, EMBEDMENT AND ON CENTER SPACING.
2. 2X MIN. WOOD OR METAL INSTALLATIONS ONLY. WOOD OR METAL MAY BE INSTALLED BY OTHERS OVER CONCRETE/MASONRY NOT SHOWN.
3. 1/4" MAX. SHIM STACK.
4. FILL LEFT & RIGHT PRE-DRILLED JAMB INSTALLATION HOLES - 6" FROM CORNER OF SILL ONLY, WITH EXTERIOR GRADE SEALANT PRIOR TO INSERTING SCREWS AND APPLY SEALANT OVER THE HEAD OF THE SCREWS ONCE PROPERLY SEATED.

TITLE: PERSPECTIVE MULTI-SLIDE PD HVHZ NON-IMPACT ANCHOR LAYOUT	DATE				
	BY				
	REVISION DESCRIPTION				
	NO.				
DATE:	09/18/23	DWN BY:	LMH	CHK BY:	SAS
				SCALE:	NTS

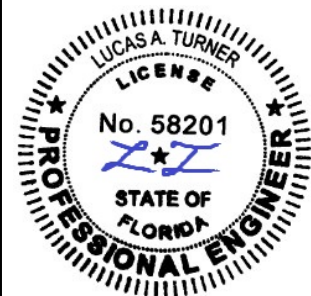

12/17/2023
LUCAS A. TURNER, P.E.
FL PE # 58201
TURNER ENGINEERING &
CONSULTING, INC.
(COA # 29779)
2428 OLD NATCHEZ TRACE
TRAIL, CAMDEN, TN 38320
PH. 941-380-1574

FL#:	41161
DWG #:	PGW347
SHEET:	14 OF 29

3 TRACK ANCHOR LAYOUT DETAILS BOX FRAME - HEAD

HEAD - DP70 (+70/-80) HVHZ Non-IMPACT

PlyGem
WINDOWS & DOORS
Part of the Cornerstone Building Brands Family
433 N. MAIN ST.,
PO BOX 559,
ROCKY MOUNT, VA 24151
PH: 540-484-6348
FX: 540-484-6683

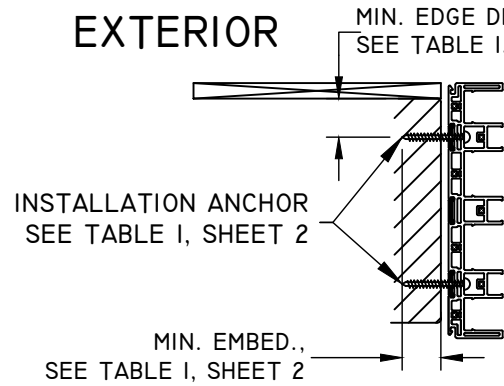

MIN. EDGE DIST.,
SEE TABLE I, SHEET 2

END HOLES

CENTER OF PANEL OR POCKET
PATTERN

INTERLOCK / ASTRAGAL PATTERN

6" FROM
CORNERS,
TYP.

INTERIOR

TYPICAL PATTERN AT SPLICE
4" MIN. ON CENTER SPACING

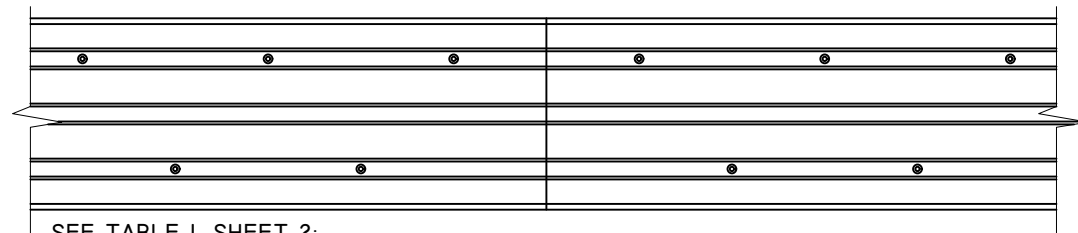

SEE TABLE I, SHEET 2:
5-0 MAX. PANEL ANCHOR ID - C, L, M, N, O, P, AND Q

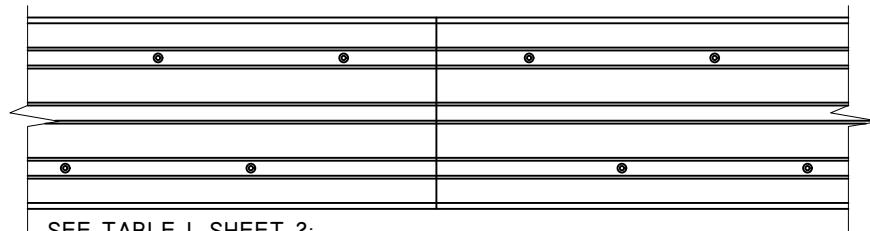

SEE TABLE I, SHEET 2:
4-0 MAX. PANEL ANCHOR ID - C, L, M, N, O, P, AND Q

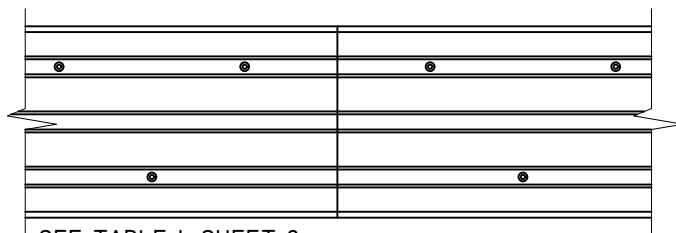

SEE TABLE I, SHEET 2:
3-0 MAX. PANEL ANCHOR ID - C, L, M, N, O, P AND Q
5-0 MAX. PANEL ANCHOR ID - A AND J



SEE TABLE I, SHEET 2:
3-0 MAX. PANEL ANCHOR ID - A, D, H AND J
4-0 MAX. PANEL ANCHOR ID - A, D, H AND J
5-0 MAX. PANEL ANCHOR ID - D AND H.

SEE TABLE I, SHEET 2:
3-0 MAX. PANEL ANCHOR ID - A, D, H AND J
4-0 MAX. PANEL ANCHOR ID - D AND H
5-0 MAX. PANEL ANCHOR ID - D

SEE TABLE I, SHEET 2:
4-0 MAX. PANEL ANCHOR ID - A AND J
5-0 MAX. PANEL ANCHOR ID - H*

SEE TABLE I, SHEET 2:
3-0 MAX. PANEL ANCHOR ID - C, L, M, N, O, P AND Q.

SEE TABLE I, SHEET 2:
5-0 MAX. PANEL ANCHOR ID - J*

SEE TABLE I, SHEET 2:
4-0 MAX. PANEL ANCHOR ID - C, L, M, N, O, P AND Q

SEE TABLE I, SHEET 2:
5-0 MAX. PANEL ANCHOR ID - C, L, M, N, O, P AND Q

NOTES:

1. INTERLOCK/ASTRAGAL INSTALLATION HOLES ARE FABRICATED BY MANUFACTURER. EXCEPTION: ANCHORS H & J.
 - 1.1. ANCHOR H*: 5-0 PANELS REQUIRE 4 ANCHOR PER CLUSTER, 3 INSTALLATION HOLES ARE PRE-DRILLED BY MANUFACTURER.
 - 1.2. ANCHOR J*: 5-0 PANELS REQUIRE 6 ANCHORS PER CLUSTER, 5 INSTALLATIONS HOLES ARE PRE-DRILLED BY MANUFACTURER.
2. SEE TABLE I, SHEET 2 FOR FASTENER MINIMUM EDGE DISTANCE, EMBEDMENT AND ON CENTER SPACING.
3. IX WOOD BUCK BY OTHERS IS OPTIONAL FOR MASONRY APPLICATIONS.
4. 1/4" MAX. SHIM STACK.
5. SPLICE DETAIL, SEE SHEET 26.

TITLE: PERSPECTIVE MULTI-SLIDE PD HVHZ Non-IMPACT ANCHOR LAYOUT	DATE			
	BY			
	REVISION DESCRIPTION			
NO.				
DATE:	DWN BY:	CHK BY:	SCALE:	NTS
09/18/23	LMH	SAS		

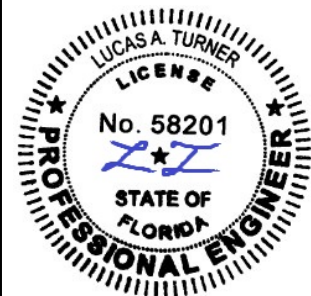

12/17/2023
LUCAS A. TURNER, P.E.
FL PE # 58201
TURNER ENGINEERING &
CONSULTING, INC.
(COA # 29779)
2428 OLD NATCHEZ TRACE
TRAIL, CAMDEN, TN 38320
PH. 941-380-1574

FL#: 41161

DWG #: PGW347

SHEET: 15 OF 29

3 TRACK ANCHOR LAYOUT DETAILS BOX FRAME - SILL

SILL - DP70 (+70/-80) HVHZ NON-IMPACT

PlyGem
WINDOWS & DOORS
Part of the Cornerstone Building Brands Family
433 N. MAIN ST.,
PO BOX 559,
ROCKY MOUNT, VA 24151
PH: 540-484-6348
FX: 540-484-6683

NOTES:

1. INTERLOCK/ASTRAGAL INSTALLATION HOLES ARE FABRICATED BY MANUFACTURER. EXCEPTION: ANCHORS H & J.
- 1.1. ANCHOR H*: 5-0 PANELS REQUIRE 4 ANCHOR PER CLUSTER, 3 INSTALLATION HOLES ARE PRE-DRILLED BY MANUFACTURER.
- 1.2. ANCHOR J*: 5-0 PANELS REQUIRE 6 ANCHORS PER CLUSTER, 5 INSTALLATIONS HOLES ARE PRE-DRILLED BY MANUFACTURER.
2. SEE TABLE 1, SHEET 2 FOR FASTENER MINIMUM EDGE DISTANCE, EMBEDMENT AND ON CENTER SPACING.
3. 1X WOOD BUCK BY OTHERS IS OPTIONAL FOR MASONRY APPLICATIONS.
4. SILL NAIL FIN IS OPTIONAL.
5. 1/4" MAX. SHIM STACK.
6. SPLICE DETAIL, SEE SHEET 26.
7. FILL ALL PRE-DRILLED INSTALLATION HOLES WITH EXTERIOR GRADE SEALANT PRIOR TO INSERTING SCREWS AND APPLY SEALANT OVER THE HEAD OF SCREWS ONCE PROPERLY SEATED.

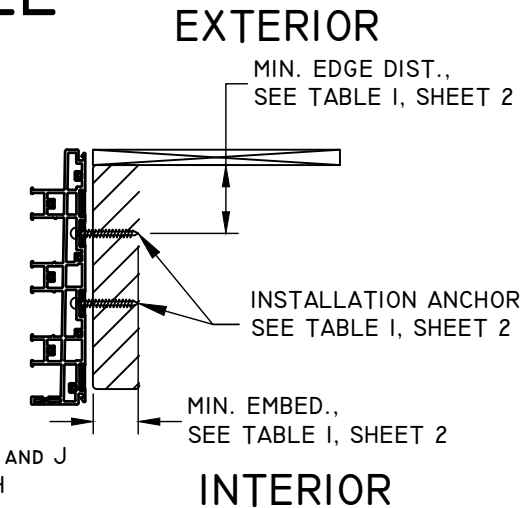
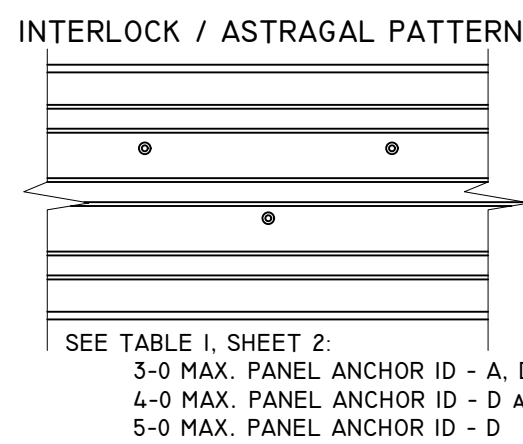
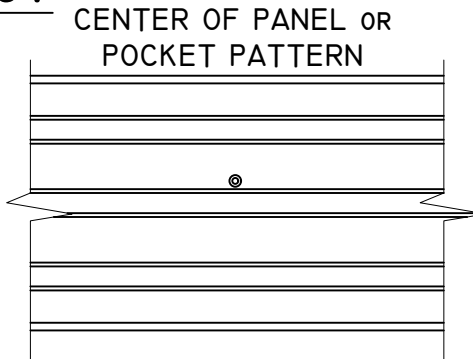
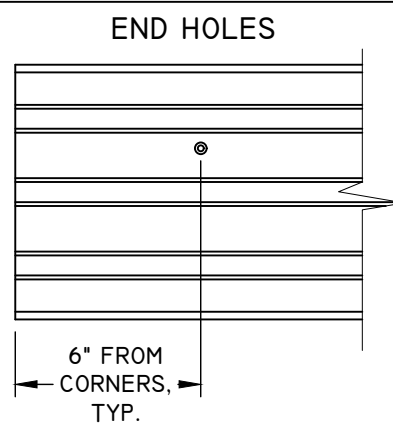

TYPICAL PATTERN AT SPLICE
4" MIN. ON CENTER SPACING

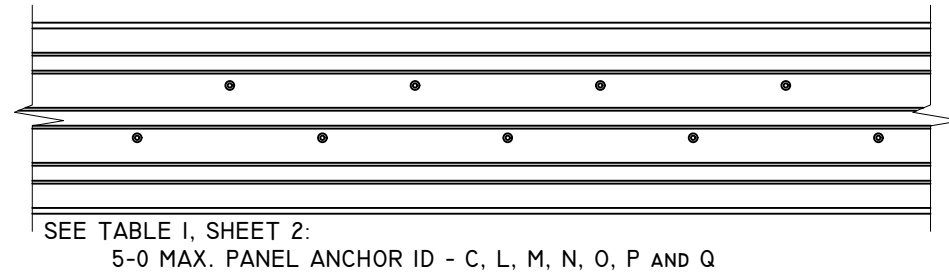
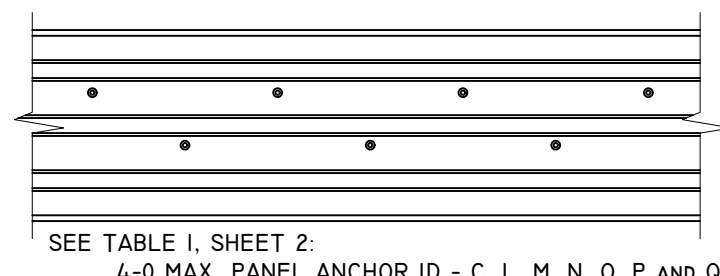
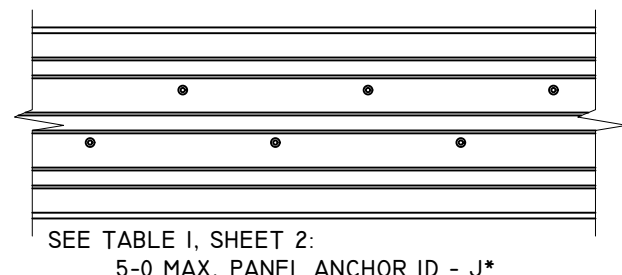
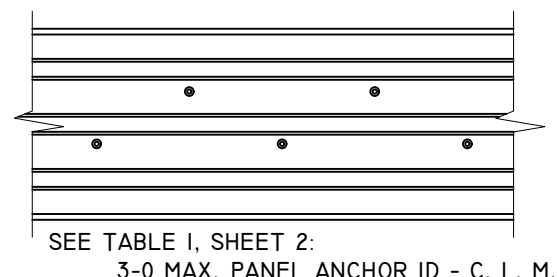
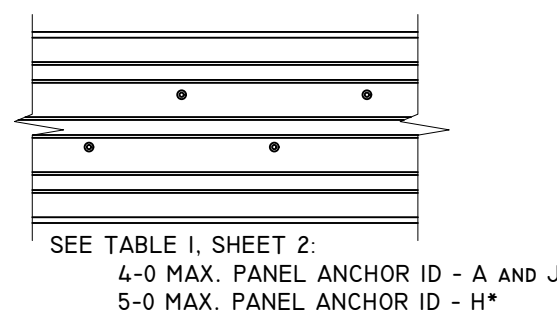
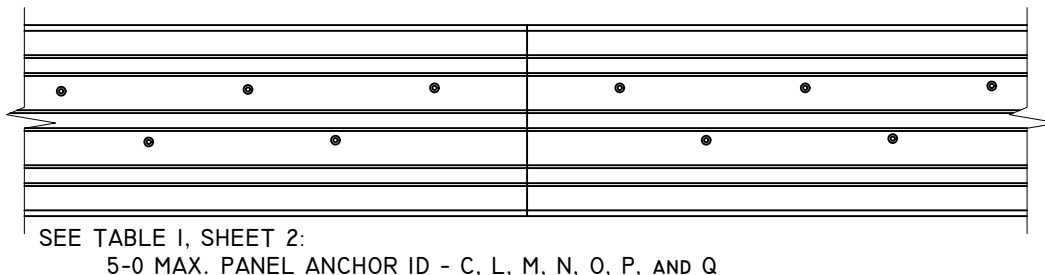
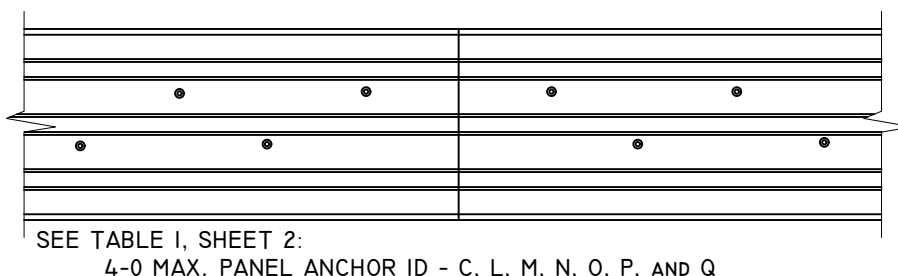
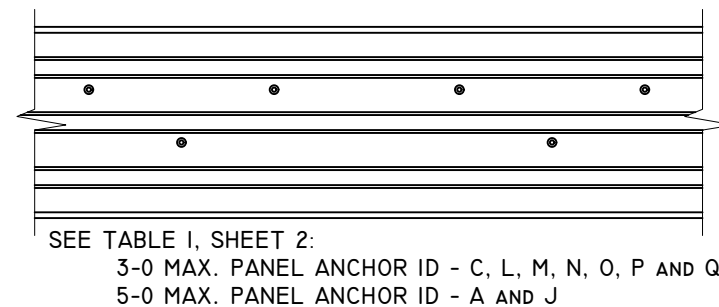
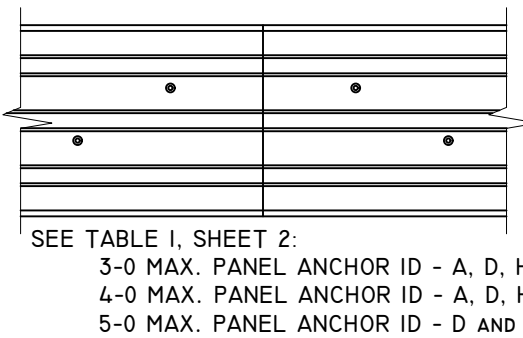

TITLE: PERSPECTIVE MULTI-SLIDE PD HVHZ NON-IMPACT ANCHOR LAYOUT	DATE			
	BY			
NO.	REVISION DESCRIPTION			
DATE: 09/18/23	DWN BY: LMH	CHK BY: SAS	SCALE: NTS	

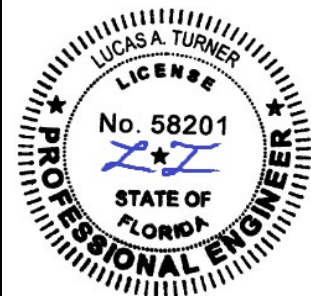

12/17/2023
LUCAS A. TURNER, P.E.
FL PE # 58201
TURNER ENGINEERING & CONSULTING, INC.
(COA # 29779)
2428 OLD NATCHEZ TRACE TRAIL, CAMDEN, TN 38320
PH. 941-380-1574

FL#: 41161
DWG #: PGW347
SHEET: 16 OF 29

3 TRACK ANCHOR LAYOUT DETAILS BOX FRAME - JAMBS

JAMB - DP70 (+70/-80) HVHZ NON-IMPACT

EXTERIOR

SEE TABLE I, SHEET 2:
ANCHOR ID - A, D, F, AND H.

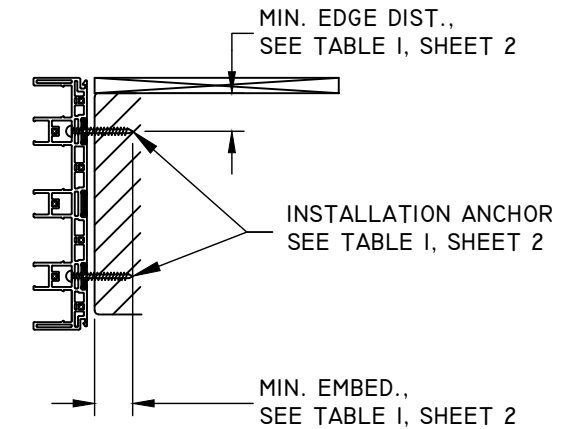
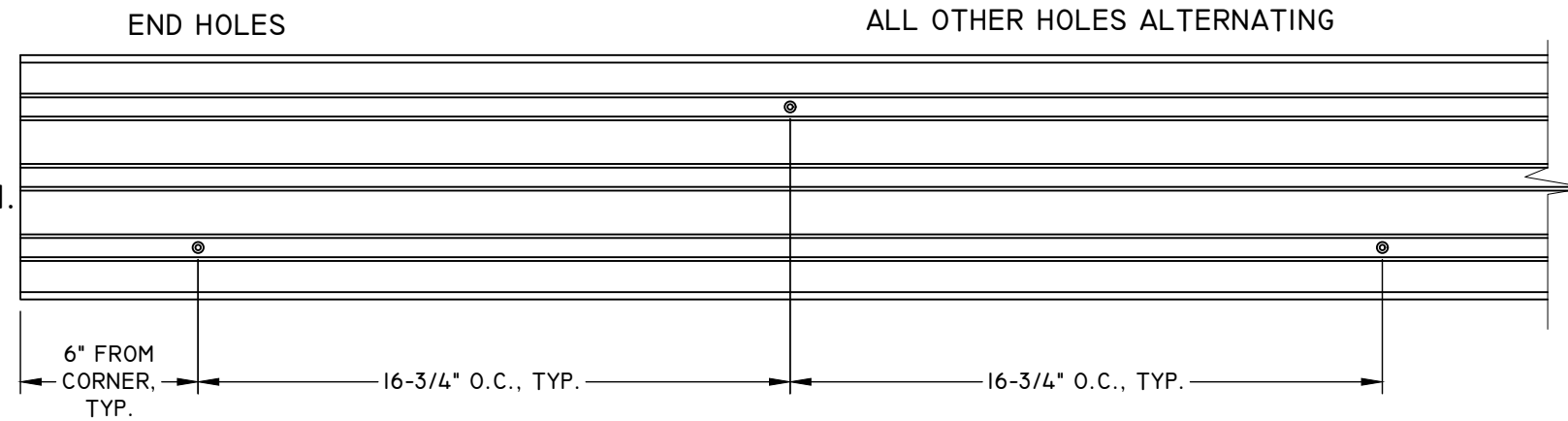

INTERIOR

SEE TABLE I, SHEET 2: ANCHOR
ID - L, M, N, O, P AND Q.

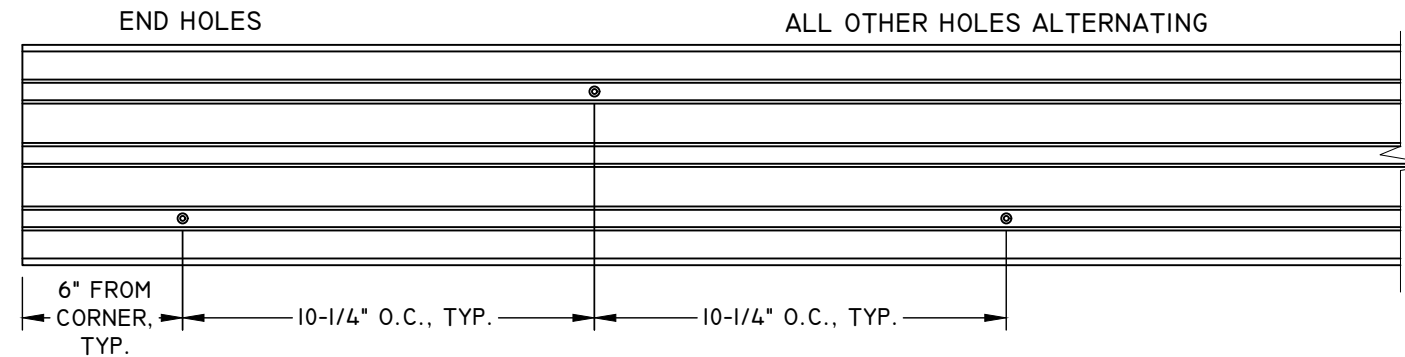

SEE TABLE I, SHEET 2: ANCHOR
ID - B, C, E, G, I, J, AND K.

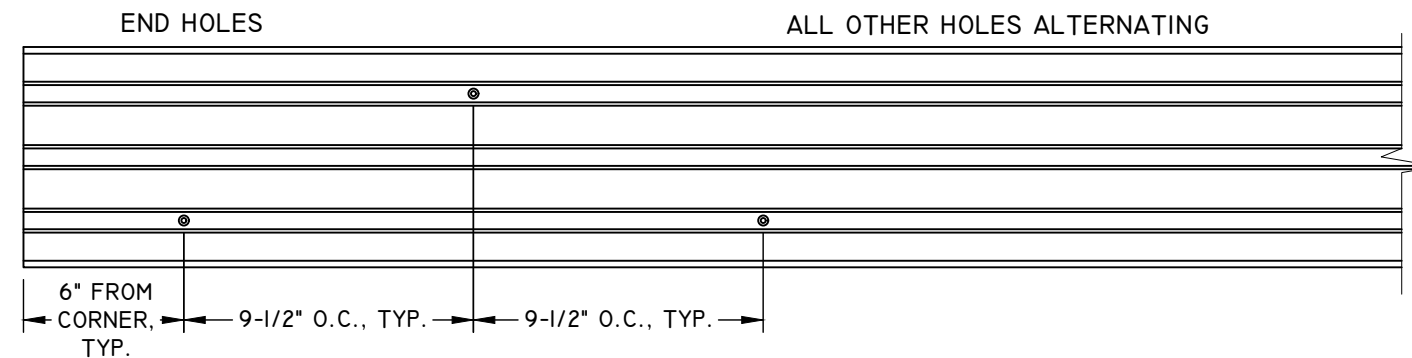

NOTES:

1. INSTALLATION HOLES ARE FABRICATED BY MANUFACTURER.
2. SEE TABLE I, SHEET 2 FOR FASTENER MINIMUM EDGE DISTANCE, EMBEDMENT AND ON CENTER SPACING.
3. IX WOOD BUCK BY OTHERS IS OPTIONAL FOR MASONRY APPLICATIONS.
4. 1/4" MAX. SHIM STACK.
5. FILL LEFT & RIGHT PRE-DRILLED JAMB INSTALLATION HOLES - 6" FROM CORNER OF SILL ONLY, WITH EXTERIOR GRADE SEALANT PRIOR TO INSERTING SCREWS AND APPLY SEALANT OVER THE HEAD OF THE SCREWS ONCE PROPERLY SEATED.

TITLE: PERSPECTIVE MULTI-SLIDE PD HVHZ NON-IMPACT ANCHOR LAYOUT	DATE			
	BY			
NO.	REVISION DESCRIPTION			
DATE: 09/18/23	DWN BY: LMH	CHK BY: SAS	SCALE: NTS	

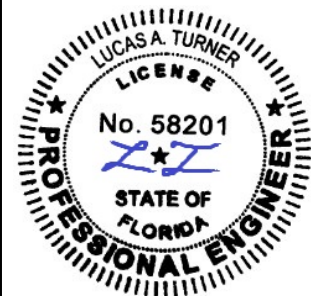

12/17/2023
LUCAS A. TURNER, P.E.
FL PE # 58201
TURNER ENGINEERING &
CONSULTING, INC.
(COA # 29779)
2428 OLD NATCHEZ TRACE
TRAIL, CAMDEN, TN 38320
PH. 941-380-1574

FL#:	41161
DWG #:	PGW347
SHEET:	17 OF 29

4 TRACK ANCHOR LAYOUT DETAILS WITH NAIL FIN - HEAD

HEAD - DP70 (+70/-80) HVHZ NON-IMPACT

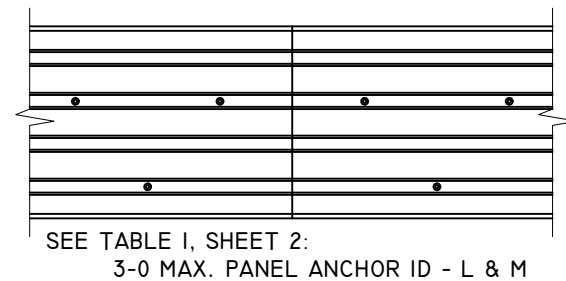
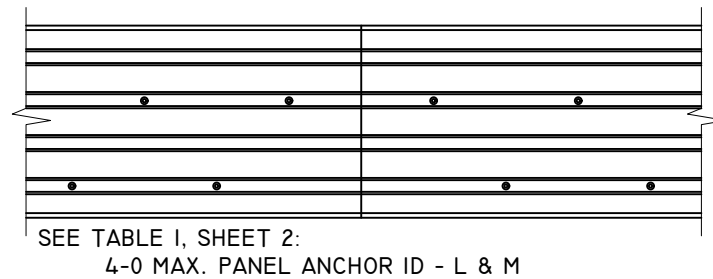
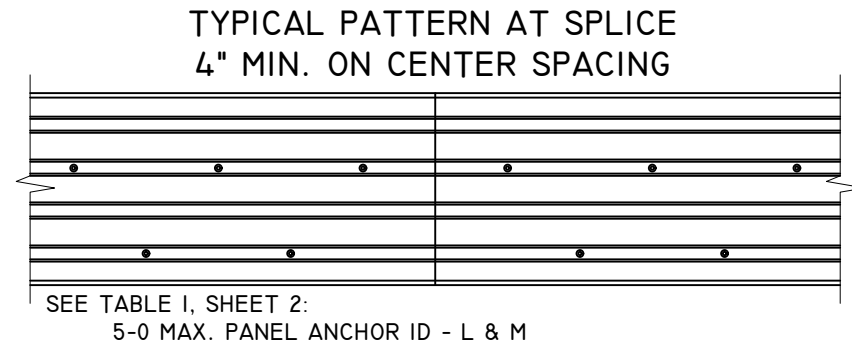
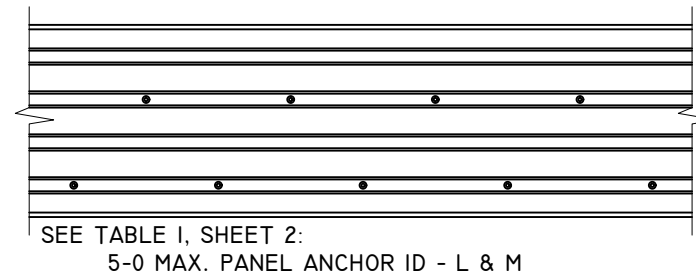
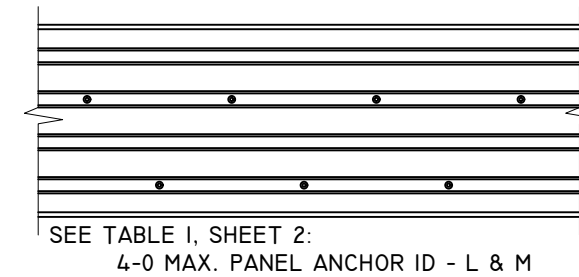
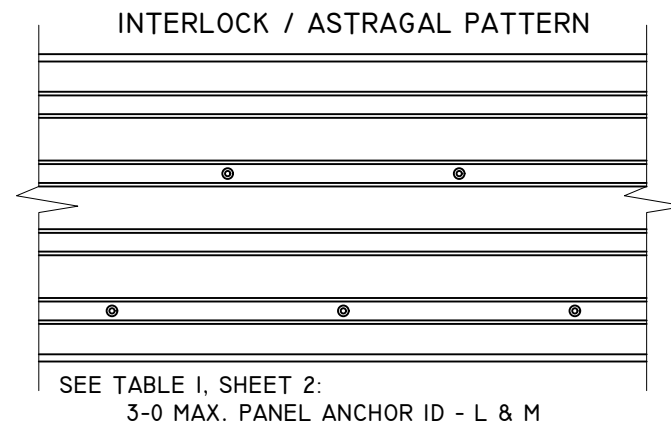
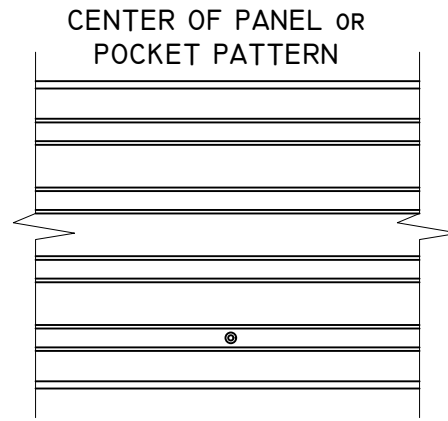
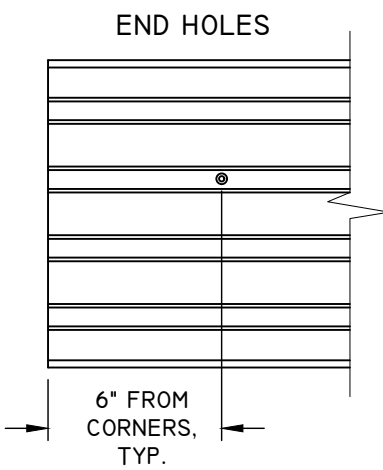
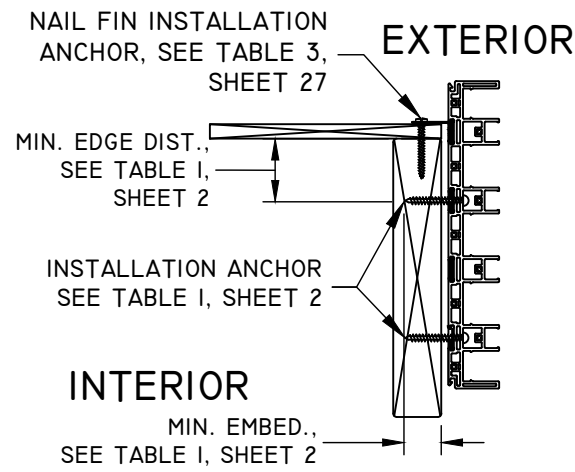

NOTES:

1. UNIT MUST BE INSTALLED WITH ANCHORS THROUGH FRAME AND THROUGH NAIL FIN SIMULTANEOUSLY.
2. 2X MIN. WOOD OR METAL INSTALLATIONS ONLY. WOOD OR METAL MAY BE INSTALLED BY OTHERS OVER CONCRETE/MASONRY NOT SHOWN.
3. SEE SHEET 27 FOR SUPPLEMENTAL INSTALLATION PATTERN THROUGH NAIL FIN, DETAIL A.
4. FRAME INSTALLATION HOLES ARE FABRICATED BY MANUFACTURER.
5. SEE TABLE 1, SHEET 2 FOR FASTENER MINIMUM EDGE DISTANCE, EMBEDMENT AND ON CENTER SPACING.
6. 1/4" MAX. SHIM STACK.
7. SPLICE DETAIL, SEE SHEET 26.

TITLE: PERSPECTIVE MULTI-SLIDE PD HVHZ NON-IMPACT ANCHOR LAYOUT	DATE			
	BY			
	REVISION DESCRIPTION			
NO.				
DATE: 09/18/23	DWN BY: LMH	CHK BY: SAS	SCALE: NTS	

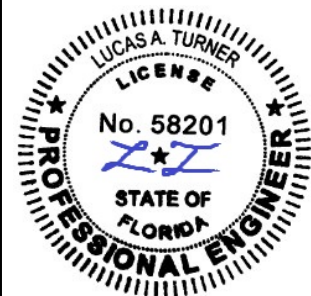

12/17/2023
LUCAS A. TURNER, P.E.
FL PE # 58201
TURNER ENGINEERING & CONSULTING, INC.
(COA # 29779)
2428 OLD NATCHEZ TRACE
TRAIL, CAMDEN, TN 38320
PH. 941-380-1574

FL#: 41161
DWG #: PGW347
SHEET: 18 OF 29

4 TRACK ANCHOR LAYOUT DETAILS WITH NAIL FIN - SILL

SILL - DP70 (+70/-80) HVHZ NON-IMPACT

PlyGem
WINDOWS & DOORS
Part of the Cornerstone Building Brands Family
433 N. MAIN ST.,
PO BOX 559,
ROCKY MOUNT, VA 24151
PH: 540-484-6348
FX: 540-484-6683

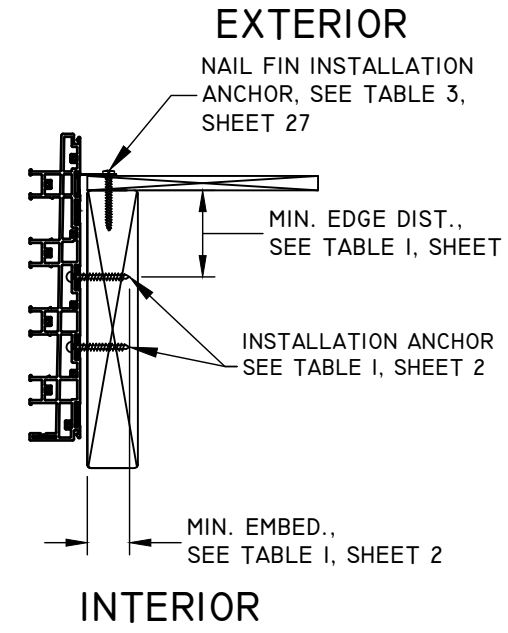
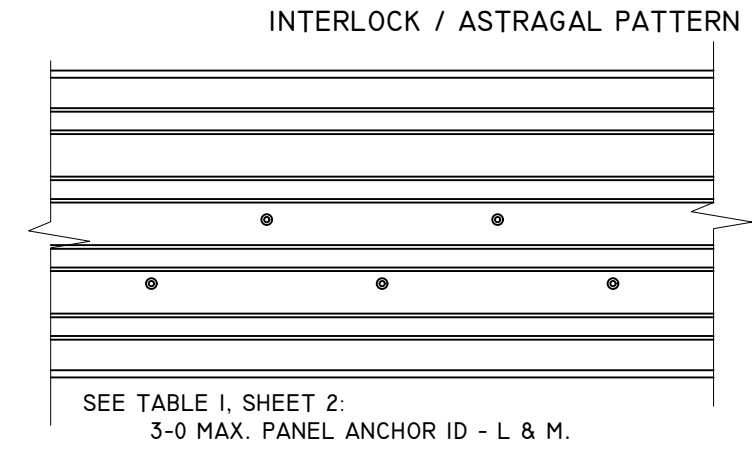
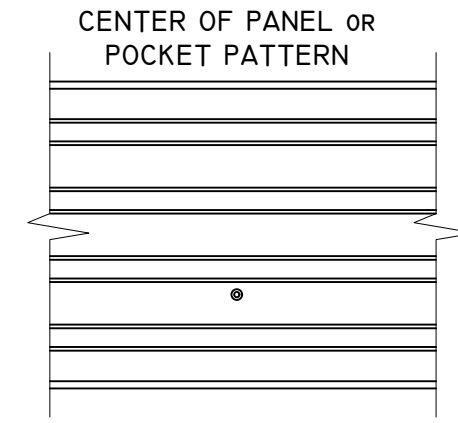
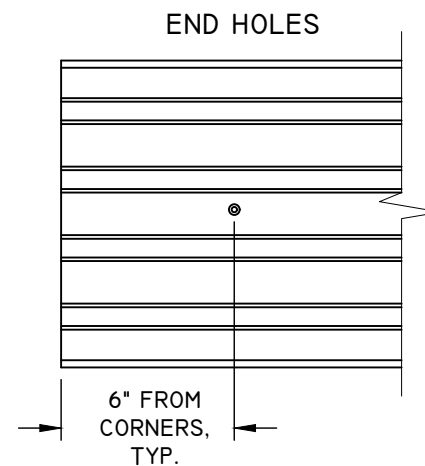

TYPICAL PATTERN AT SPLICE
4" MIN. ON CENTER SPACING

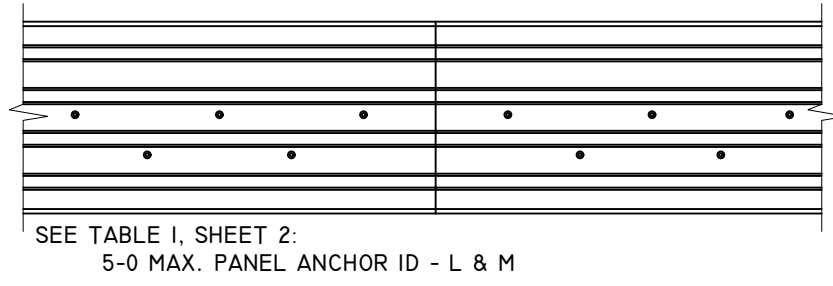
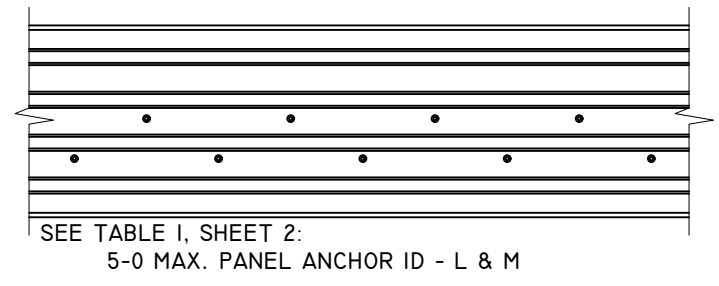
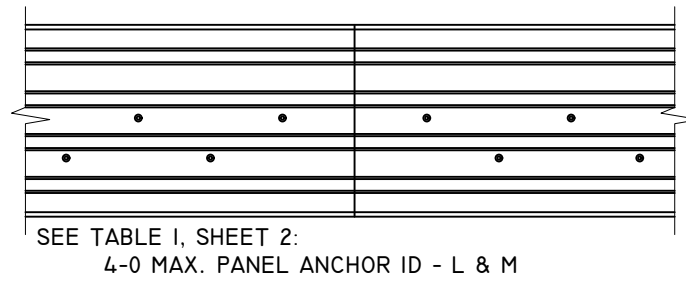
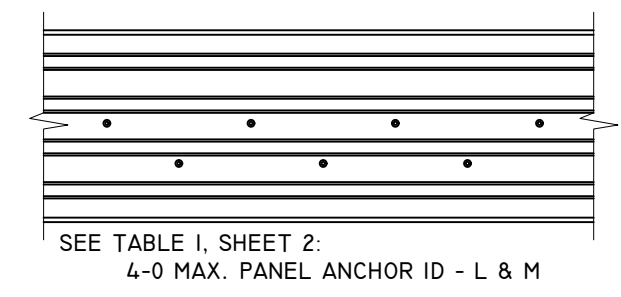
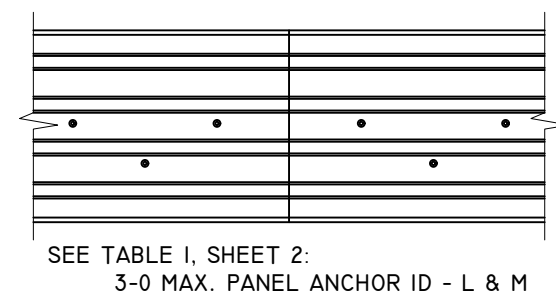

NOTES:

1. UNIT MUST BE INSTALLED WITH ANCHORS THROUGH FRAME AND THROUGH NAIL FIN SIMULTANEOUSLY.
2. 2X MIN. WOOD OR METAL INSTALLATIONS ONLY. WOOD OR METAL MAY BE INSTALLED BY OTHERS OVER CONCRETE/MASONRY, NOT SHOWN.
3. SEE SHEET 27 FOR SUPPLEMENTAL INSTALLATION PATTERN THROUGH NAIL FIN, DETAIL B - ALTERNATE.
4. FRAME INSTALLATION HOLES ARE FABRICATED BY MANUFACTURER.
5. SEE TABLE I, SHEET 2 FOR FASTENER MINIMUM EDGE DISTANCE, EMBEDMENT AND ON CENTER SPACING.
6. 1/4" MAX. SHIM STACK.
7. SPLICE DETAIL, SEE SHEET 26.
8. FILL ALL PRE-DRILLED INSTALLATION HOLES WITH EXTERIOR GRADE SEALANT PRIOR TO INSERTING SCREWS AND APPLY SEALANT OVER THE HEAD OF SCREWS ONCE PROPERLY SEATED.

TITLE: PERSPECTIVE MULTI-SLIDE PD HVHZ NON-IMPACT ANCHOR LAYOUT	DATE			
	BY			
NO.	REVISION DESCRIPTION			
DATE: 09/18/23	DWN BY: LMH	CHK BY: SAS	SCALE: NTS	



12/17/2023
LUCAS A. TURNER, P.E.
FL PE # 58201
TURNER ENGINEERING & CONSULTING, INC.
(COA # 29779)
2428 OLD NATCHEZ TRACE
TRAIL, CAMDEN, TN 38320
PH. 941-380-1574

FL#: 41161
DWG #: PGW347
SHEET: 19 OF 29

4 TRACK ANCHOR LAYOUT DETAILS WITH NAIL FIN - JAMBS

JAMB - DP70 (+70/-80) HVHZ NON-IMPACT

SEE TABLE I, SHEET 2:
ANCHOR ID - L & M.

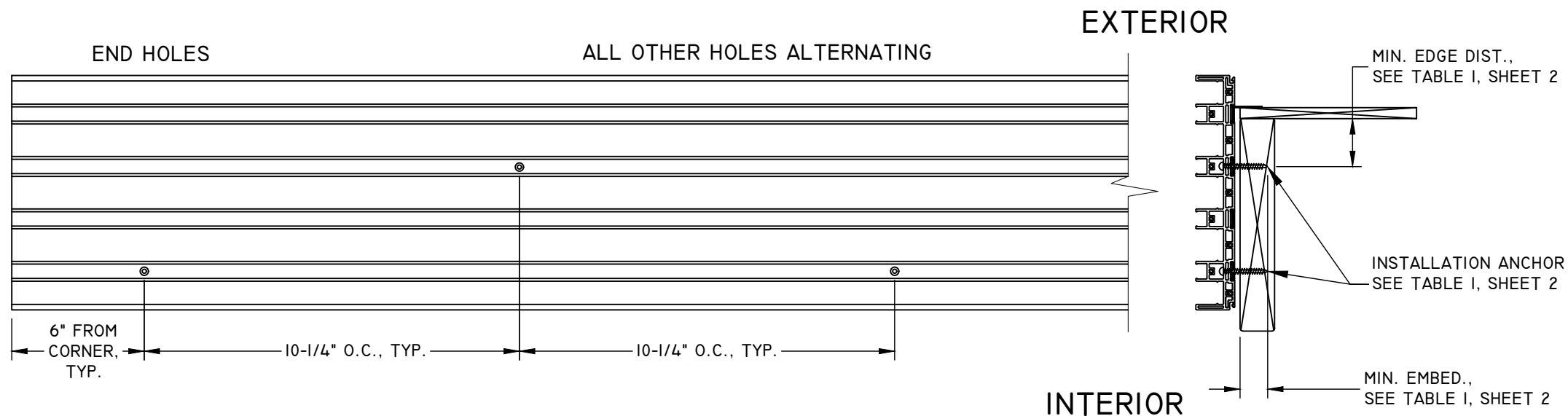

NOTES:

1. INSTALLATION HOLES ARE FABRICATED BY MANUFACTURER.
2. SEE TABLE I, SHEET 2 FOR FASTENER MINIMUM EDGE DISTANCE, EMBEDMENT AND ON CENTER SPACING.
2. 2X MIN. WOOD OR METAL INSTALLATIONS ONLY. WOOD OR METAL MAY BE INSTALLED BY OTHERS OVER CONCRETE/MASONRY NOT SHOWN.
3. 1/4" MAX. SHIM STACK.
4. FILL LEFT & RIGHT PRE-DRILLED JAMB INSTALLATION HOLES - 6" FROM CORNER OF SILL ONLY, WITH EXTERIOR GRADE SEALANT PRIOR TO INSERTING SCREWS AND APPLY SEALANT OVER THE HEAD OF THE SCREWS ONCE PROPERLY SEATED.

Ply Gem
WINDOWS & DOORS
Part of the Cornerstone Building Brands Family
433 N. MAIN ST.,
PO BOX 559,
ROCKY MOUNT, VA 24151
PH: 540-484-6348
FX: 540-484-6683

TITLE: PERSPECTIVE MULTI-SLIDE PD HVHZ NON-IMPACT ANCHOR LAYOUT	DATE			
	BY			
NO.	REVISION DESCRIPTION			
DATE: 09/18/23	DWN BY: LMH	CHK BY: SAS	SCALE: NTS	



12/17/2023
LUCAS A. TURNER, P.E.
FL PE # 58201
TURNER ENGINEERING & CONSULTING, INC.
(COA # 29779)
2428 OLD NATCHEZ TRACE
TRAIL, CAMDEN, TN 38320
PH. 941-380-1574

FL#: 41161

DWG #: PGW347

SHEET: 20 OF 29

4 TRACK ANCHOR LAYOUT DETAILS BOX FRAME - HEAD

HEAD - DP70 (+70/-80) HVHZ NON-IMPACT

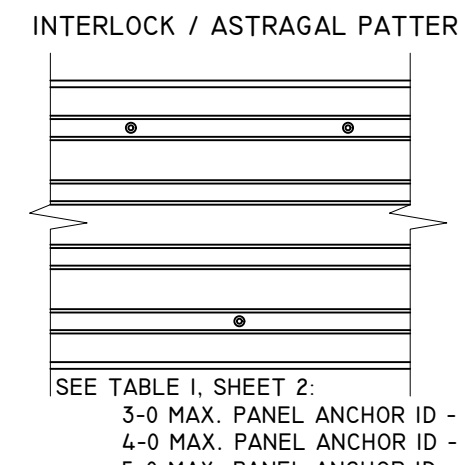
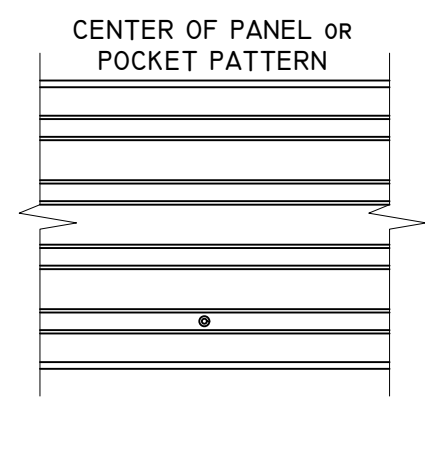
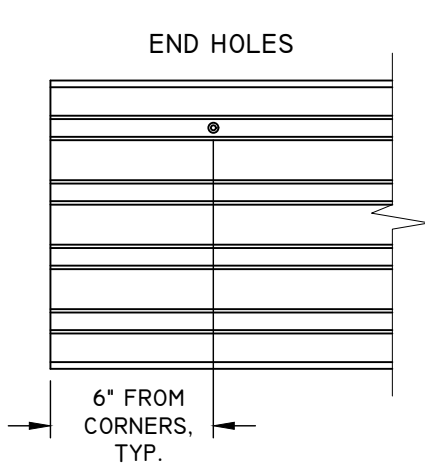
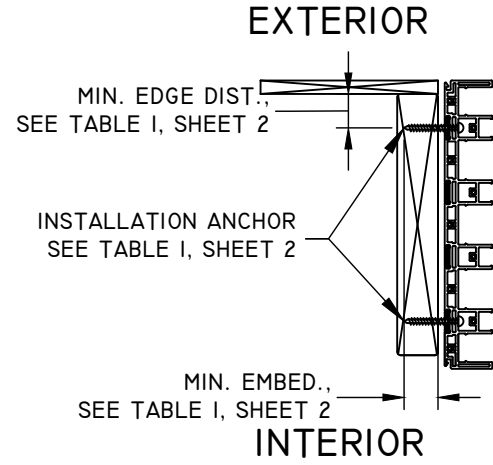

SEE TABLE I, SHEET 2:
3-0 MAX. PANEL ANCHOR ID - A, D, H AND J
4-0 MAX. PANEL ANCHOR ID - D AND H
5-0 MAX. PANEL ANCHOR ID - D

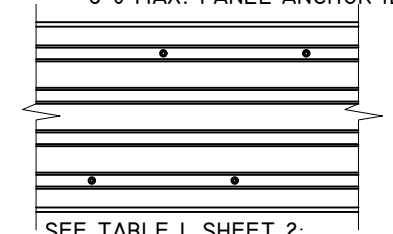

SEE TABLE I, SHEET 2:
4-0 MAX. PANEL ANCHOR ID - A AND J
5-0 MAX. PANEL ANCHOR ID - H*

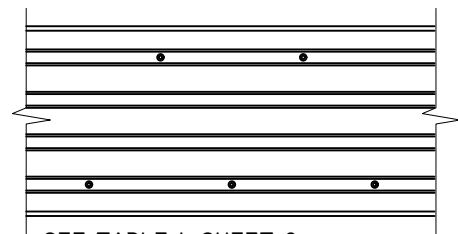

SEE TABLE I, SHEET 2:
3-0 MAX. PANEL ANCHOR ID - C, L, M, N, O, P AND Q.

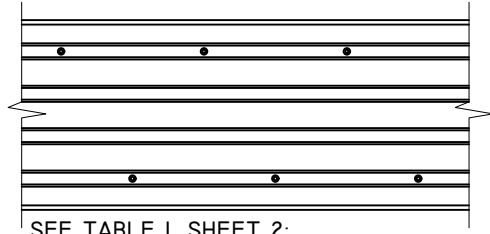

SEE TABLE I, SHEET 2:
5-0 MAX. PANEL ANCHOR ID - J*

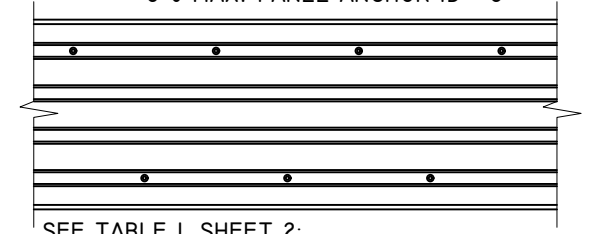

SEE TABLE I, SHEET 2:
4-0 MAX. PANEL ANCHOR ID - C, L, M, N, O, P AND Q

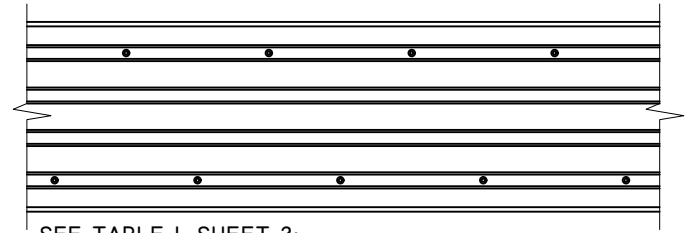

SEE TABLE I, SHEET 2:
5-0 MAX. PANEL ANCHOR ID - C, L, M, N, O, P AND Q

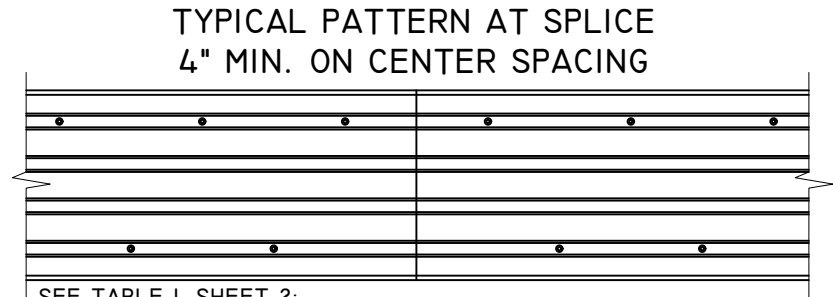

SEE TABLE I, SHEET 2:
5-0 MAX. PANEL ANCHOR ID - C, L, M, N, O, P, AND Q

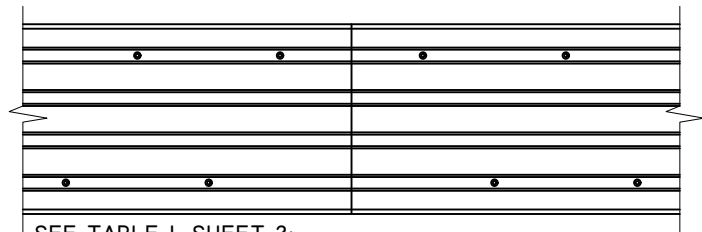

SEE TABLE I, SHEET 2:
4-0 MAX. PANEL ANCHOR ID - C, L, M, N, O, P, AND Q

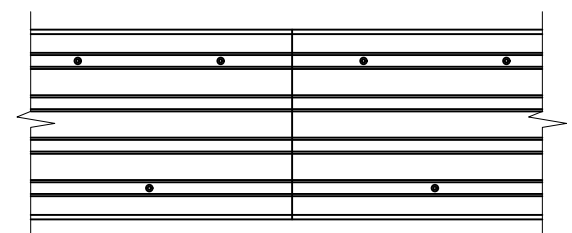

SEE TABLE I, SHEET 2:
3-0 MAX. PANEL ANCHOR ID - C, L, M, N, O, P AND Q
5-0 MAX. PANEL ANCHOR ID - A AND J

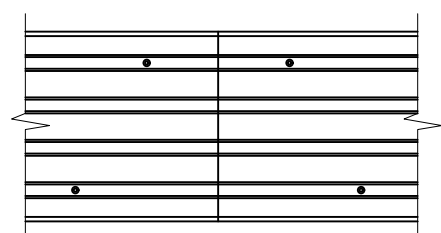

SEE TABLE I, SHEET 2:
3-0 MAX. PANEL ANCHOR ID - A, D, H AND J
4-0 MAX. PANEL ANCHOR ID - A, D, H AND J
5-0 MAX. PANEL ANCHOR ID - D AND H.

- NOTES:**
1. SUBSTRATE
 - 1.1. WOOD STUD
 2. INTERLOCK/ASTRAGAL INSTALLATION HOLES ARE FABRICATED BY MANUFACTURER. EXCEPTION: ANCHORS H & J.
 - 2.1. ANCHOR H*: 5-0 PANELS REQUIRE 4 ANCHOR PER CLUSTER, 3 INSTALLATION HOLES ARE PRE-DRILLED BY MANUFACTURER.
 - 2.2. ANCHOR J*: 5-0 PANELS REQUIRE 6 ANCHORS PER CLUSTER, 5 INSTALLATIONS HOLES ARE PRE-DRILLED BY MANUFACTURER.
 3. SEE TABLE I, SHEET 2 FOR FASTENER MINIMUM EDGE DISTANCE, EMBEDMENT AND ON CENTER SPACING.
 4. IX WOOD BUCK BY OTHERS IS OPTIONAL FOR MASONRY APPLICATIONS.
 5. 1/4" MAX. SHIM STACK.
 6. SPLICE DETAIL, SEE SHEET 26.

TITLE: PERSPECTIVE MULTI-SLIDE PD HVHZ NON-IMPACT ANCHOR LAYOUT	DATE			
	BY			
	REVISION DESCRIPTION			
NO.				
DATE: 09/18/23	DWN BY: LMH	CHK BY: SAS	SCALE: NTS	

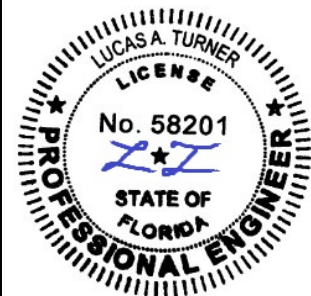

12/17/2023
LUCAS A. TURNER, P.E.
FL PE # 58201
TURNER ENGINEERING & CONSULTING, INC.
(COA # 29779)
2428 OLD NATCHEZ TRACE TRAIL, CAMDEN, TN 38320
PH. 941-380-1574

FL#: 41161
DWG #: PGW347
SHEET: 21 OF 29

4 TRACK ANCHOR LAYOUT DETAILS WITH BOX FRAME - HEAD

HEAD - DP70 (+70/-80) HVHZ Non-IMPACT

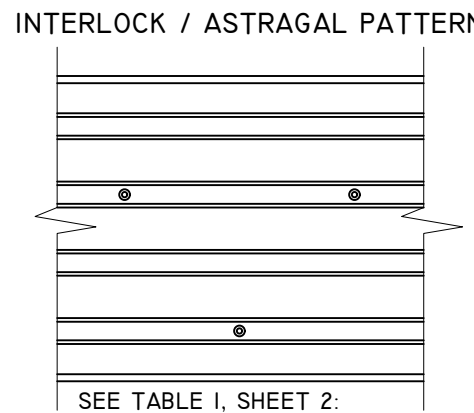
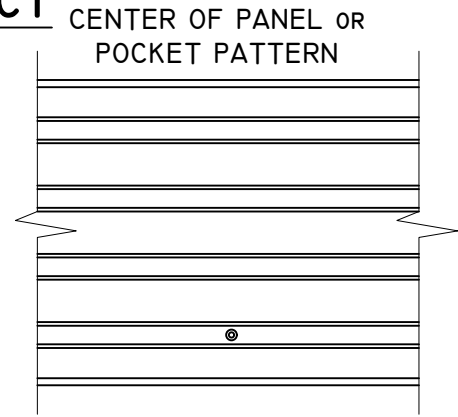
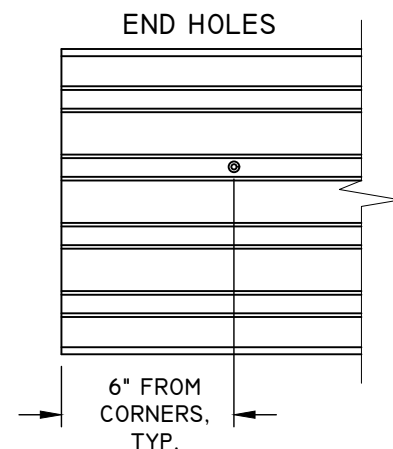
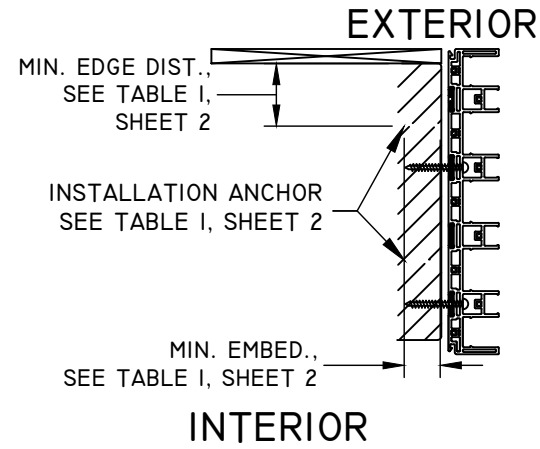

SEE TABLE I, SHEET 2:
3-0 MAX. PANEL ANCHOR ID - A, D, H AND J
4-0 MAX. PANEL ANCHOR ID - D AND H
5-0 MAX. PANEL ANCHOR ID - D

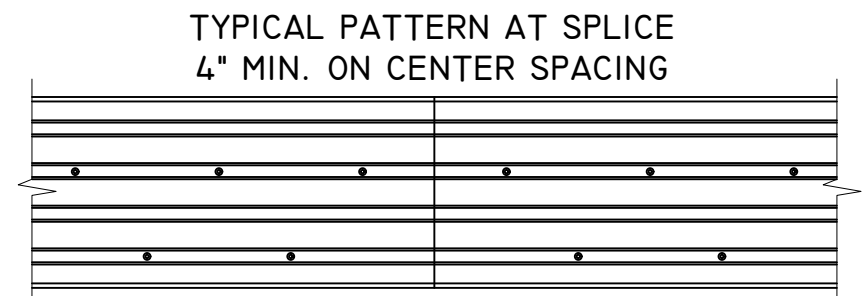

SEE TABLE I, SHEET 2:
5-0 MAX. PANEL ANCHOR ID - C, L, M, N, O, P, AND Q

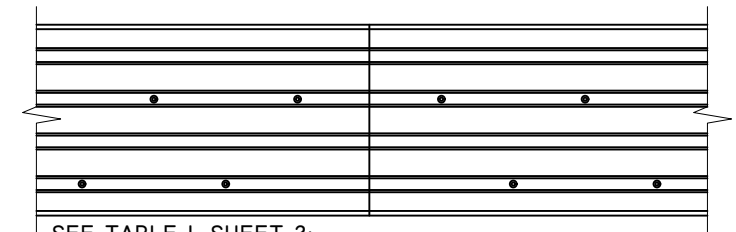

SEE TABLE I, SHEET 2:
4-0 MAX. PANEL ANCHOR ID - C, L, M, N, O, P, AND Q

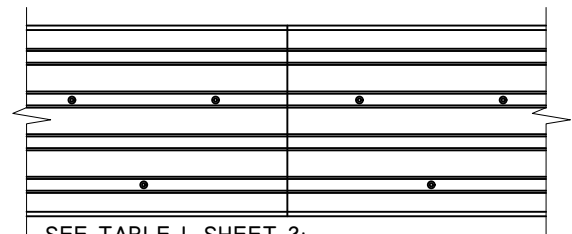

SEE TABLE I, SHEET 2:
3-0 MAX. PANEL ANCHOR ID - C, L, M, N, O, P AND Q
5-0 MAX. PANEL ANCHOR ID - A AND J

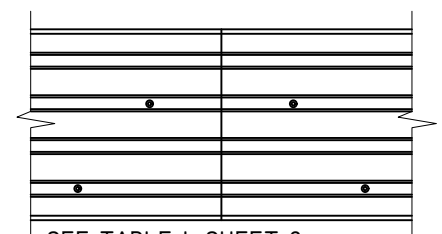

SEE TABLE I, SHEET 2:
3-0 MAX. PANEL ANCHOR ID - A, D, H AND J
4-0 MAX. PANEL ANCHOR ID - A, D, H AND J
5-0 MAX. PANEL ANCHOR ID - D AND H.

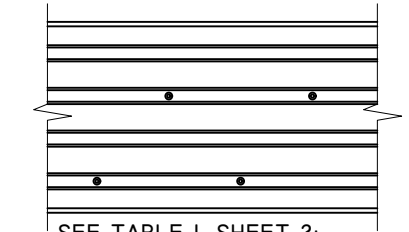

SEE TABLE I, SHEET 2:
4-0 MAX. PANEL ANCHOR ID - A AND J
5-0 MAX. PANEL ANCHOR ID - H*

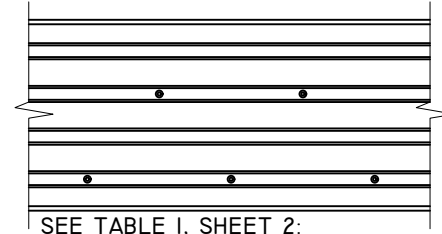

SEE TABLE I, SHEET 2:
3-0 MAX. PANEL ANCHOR ID - C, L, M, N, O, P AND Q.

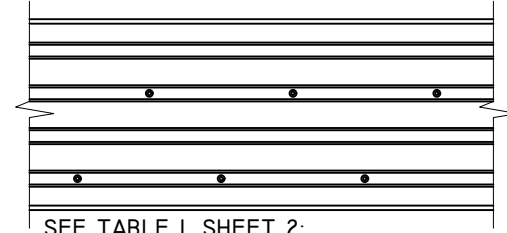

SEE TABLE I, SHEET 2:
5-0 MAX. PANEL ANCHOR ID - J*

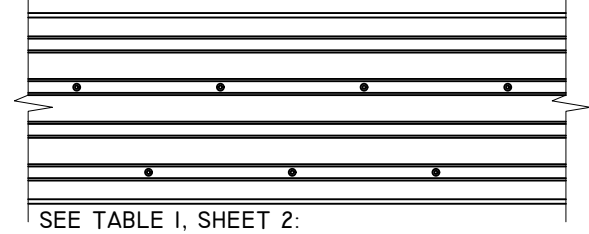

SEE TABLE I, SHEET 2:
4-0 MAX. PANEL ANCHOR ID - C, L, M, N, O, P AND Q

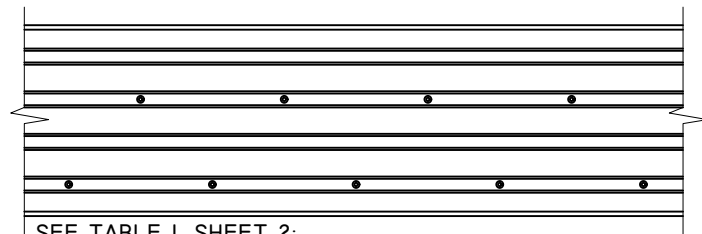

SEE TABLE I, SHEET 2:
5-0 MAX. PANEL ANCHOR ID - C, L, M, N, O, P AND Q

NOTES:

1. SUBSTRATE
 - 1.1. MASONRY
 - 1.2. STEEL/ALUMINUM STUD
2. INTERLOCK/ASTRAGAL INSTALLATION HOLES ARE FABRICATED BY MANUFACTURER. EXCEPTION: ANCHORS H & J.
 - 2.1. ANCHOR H*: 5-0 PANELS REQUIRE 4 ANCHOR PER CLUSTER, 3 INSTALLATION HOLES ARE PRE-DRILLED BY MANUFACTURER.
 - 2.2. ANCHOR J*: 5-0 PANELS REQUIRE 6 ANCHORS PER CLUSTER, 5 INSTALLATIONS HOLES ARE PRE-DRILLED BY MANUFACTURER.
3. SEE TABLE I, SHEET 2 FOR FASTENER MINIMUM EDGE DISTANCE, EMBEDMENT AND ON CENTER SPACING.
4. IX WOOD BUCK BY OTHERS IS OPTIONAL FOR MASONRY APPLICATIONS.
5. 1/4" MAX. SHIM STACK.
6. SPLICE DETAIL, SEE SHEET 26.

TITLE: PERSPECTIVE MULTI-SLIDE PD HVHZ Non-IMPACT ANCHOR LAYOUT	DATE			
	BY			
	REVISION DESCRIPTION			
NO.				
DATE:	DWN BY:	CHK BY:	SCALE:	NTS
09/18/23	LMH	SAS		



12/17/2023
LUCAS A. TURNER, P.E.
FL PE # 58201
TURNER ENGINEERING & CONSULTING, INC.
(COA # 29779)
2428 OLD NATCHEZ TRACE TRAIL, CAMDEN, TN 38320
PH. 941-380-1574

FL#:	41161
DWG #:	PGW347
SHEET:	22 OF 29

4 TRACK ANCHOR LAYOUT DETAILS BOX FRAME - SILL

SILL - DP70 (+70/-80) HVHZ NON-IMPACT

NOTES:

1. INTERLOCK/ASTRAGAL INSTALLATION HOLES ARE FABRICATED BY MANUFACTURER. EXCEPTION: ANCHORS H & J.
 - 1.1. ANCHOR H*: 5-0 PANELS REQUIRE 4 ANCHOR PER CLUSTER, 3 INSTALLATION HOLES ARE PRE-DRILLED BY MANUFACTURER.
 - 1.2. ANCHOR J*: 5-0 PANELS REQUIRE 6 ANCHORS PER CLUSTER, 5 INSTALLATIONS HOLES ARE PRE-DRILLED BY MANUFACTURER.
2. SEE TABLE I, SHEET 2 FOR FASTENER MINIMUM EDGE DISTANCE, EMBEDMENT AND ON CENTER SPACING.
3. 1X WOOD BUCK BY OTHERS IS OPTIONAL FOR MASONRY APPLICATIONS.
4. SILL NAIL FIN IS OPTIONAL.
5. 1/4" MAX. SHIM STACK.
6. SPLICE DETAIL, SEE SHEET 26.
7. FILL ALL PRE-DRILLED INSTALLATION HOLES WITH EXTERIOR GRADE SEALANT PRIOR TO INSERTING SCREWS AND APPLY SEALANT OVER THE HEAD OF SCREWS ONCE PROPERLY SEATED.

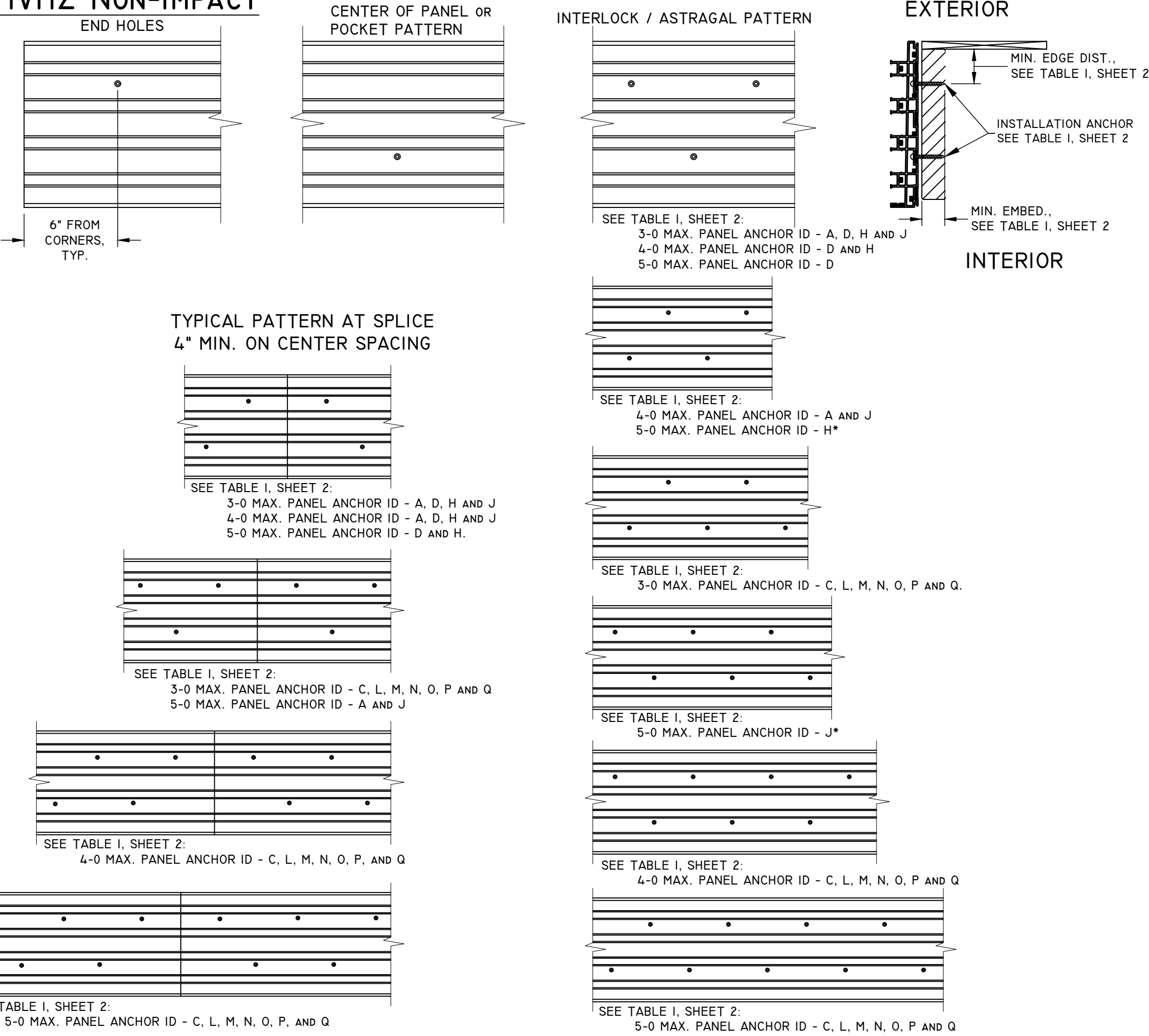

PlyGem
WINDOWS & DOORS
Part of the Cornerstone Building Brands Family
433 N. MAIN ST.,
PO BOX 559,
ROCKY MOUNT, VA 24151
PH: 540-484-6348
FX: 540-484-6683

TITLE: PERSPECTIVE MULTI-SLIDE PD HVHZ NON-IMPACT ANCHOR LAYOUT	DATE			
	BY			
NO.	REVISION DESCRIPTION			
	DATE			
DATE: 09/18/23	DWN BY: LMH	CHK BY: SAS	SCALE: NTS	

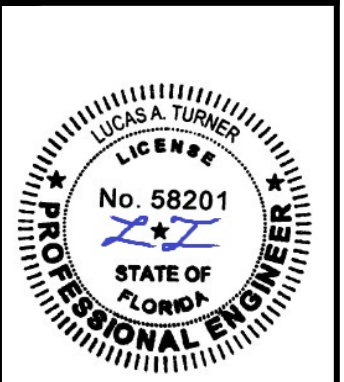

12/17/2023
LUCAS A. TURNER, P.E.
FL PE # 58201
TURNER ENGINEERING & CONSULTING, INC.
(COA # 29779)
2428 OLD NATCHEZ TRACE TRAIL, CAMDEN, TN 38320
PH. 941-380-1574

FL#: **41161**
DWG #: **PGW347**
SHEET: **23 OF 29**

4 TRACK ANCHOR LAYOUT DETAILS BOX FRAME - JAMBS

JAMB - DP70 (+70/-80) HVHZ Non-IMPACT

SEE TABLE I, SHEET 2:
ANCHOR ID - A, D, F, AND H.

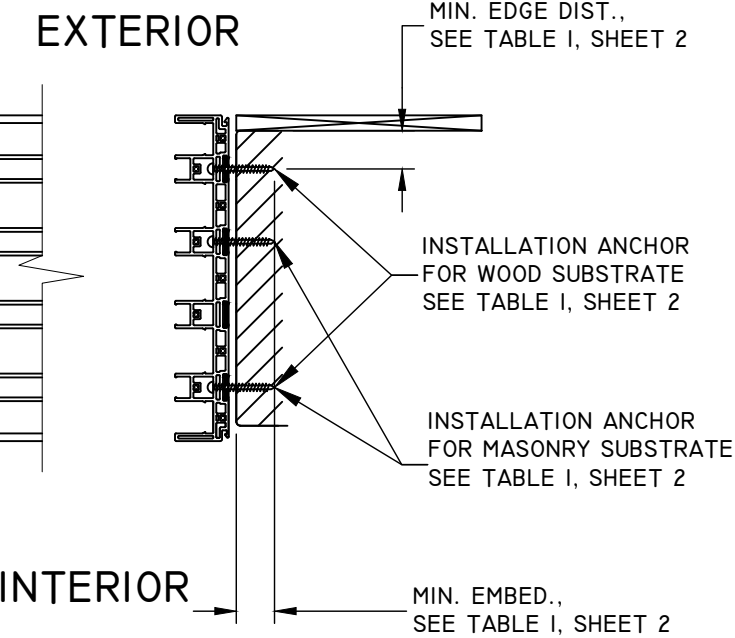
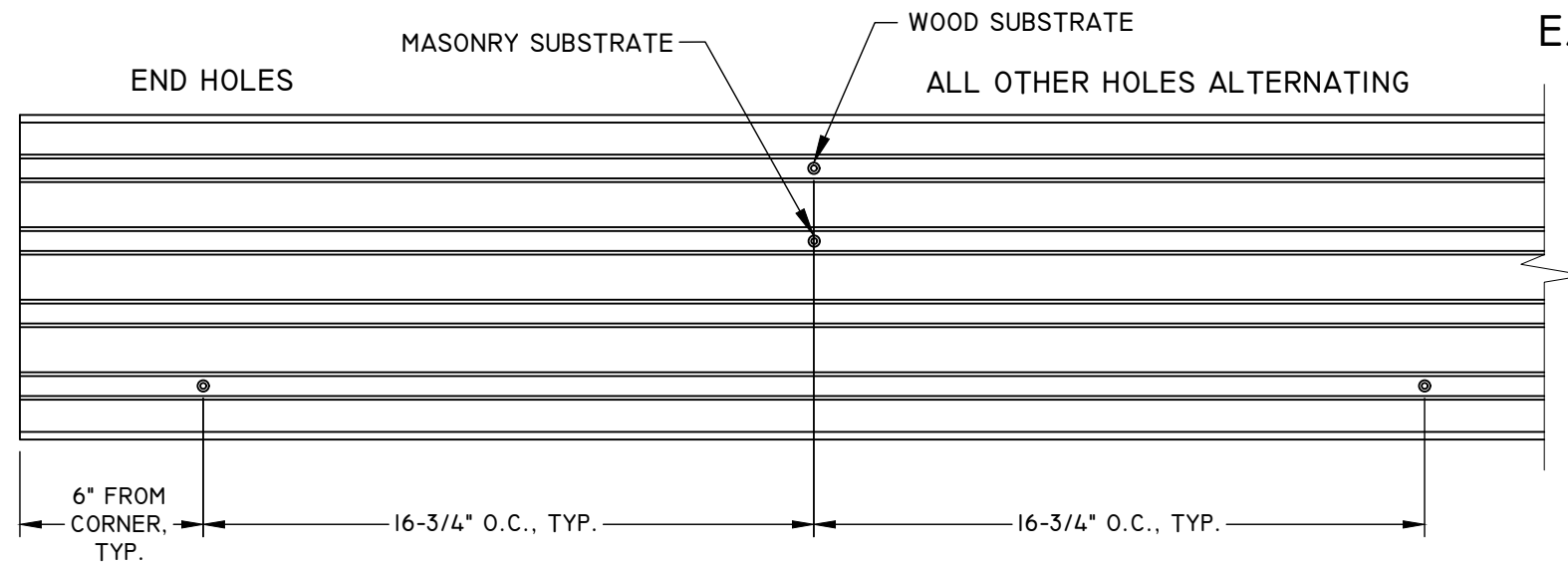

SEE TABLE I, SHEET 2: ANCHOR
ID - L, M, N, O, P AND Q.

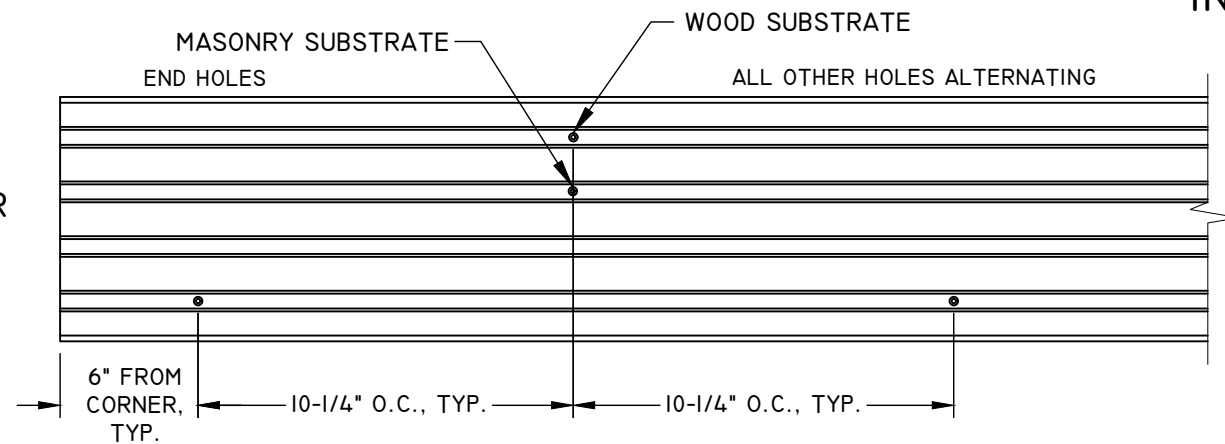

SEE TABLE I, SHEET 2: ANCHOR
ID - B, C, E, G, I, J, AND K.

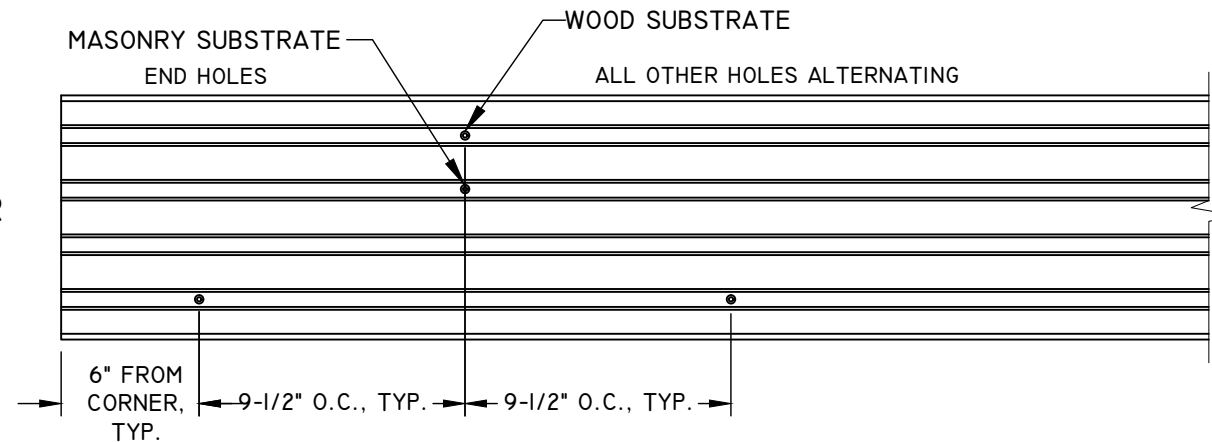

NOTES:

1. INSTALLATION HOLES ARE FABRICATED BY MANUFACTURER.
2. SEE TABLE I, SHEET 2 FOR FASTENER MINIMUM EDGE DISTANCE, EMBEDMENT AND ON CENTER SPACING.
3. IX WOOD BUCK BY OTHERS IS OPTIONAL FOR MASONRY APPLICATIONS.
4. 1/4" MAX. SHIM STACK.
5. FILL LEFT & RIGHT PRE-DRILLED JAMB INSTALLATION HOLES - 6" FROM CORNER OF SILL ONLY, WITH EXTERIOR GRADE SEALANT PRIOR TO INSERTING SCREWS AND APPLY SEALANT OVER THE HEAD OF THE SCREWS ONCE PROPERLY SEATED.

TITLE: PERSPECTIVE MULTI-SLIDE PD HVHZ Non-IMPACT ANCHOR LAYOUT	DATE			
	BY			
NO.	REVISION DESCRIPTION			
DATE: 09/18/23	DWN BY: LMH	CHK BY: SAS	SCALE: NTS	



12/17/2023
LUCAS A. TURNER, P.E.
FL PE # 58201
TURNER ENGINEERING &
CONSULTING, INC.
(COA # 29779)
2428 OLD NATCHEZ TRACE
TRAIL, CAMDEN, TN 38320
PH. 941-380-1574

FL#:	41161
DWG #:	PGW347
SHEET:	24 OF 29

P-HOOK ANCHOR LAYOUT

DETAIL E4
P-HOOK

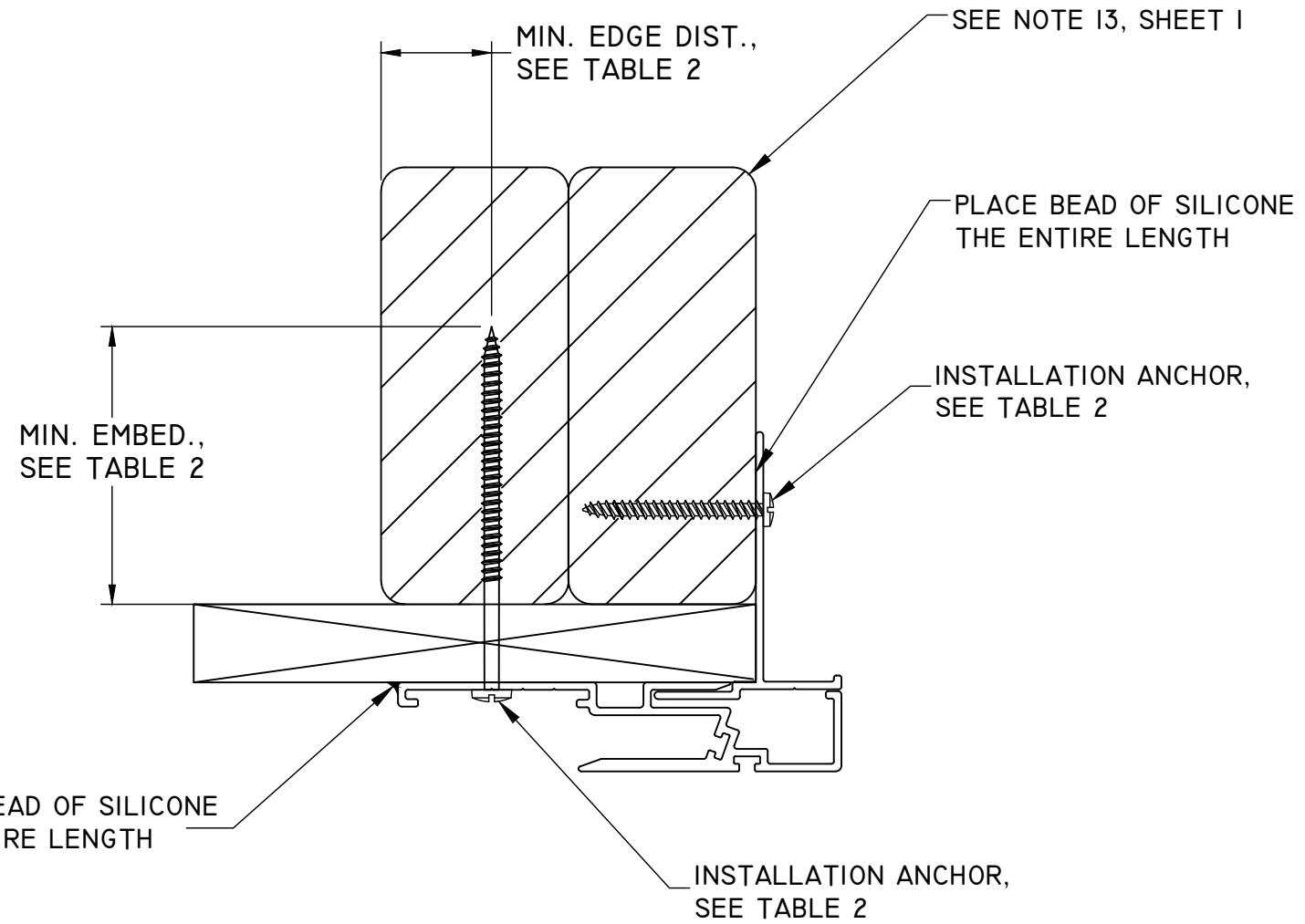
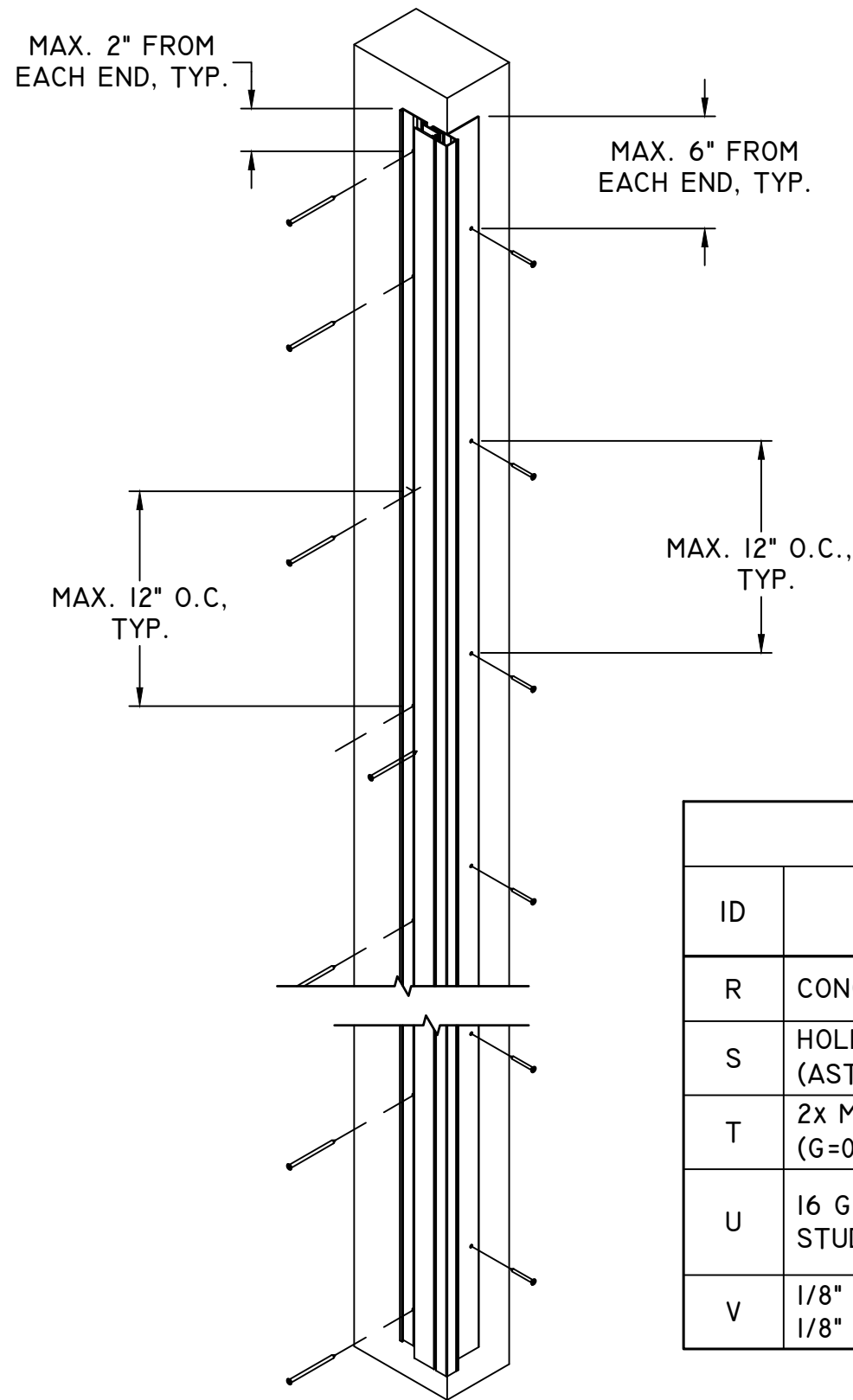
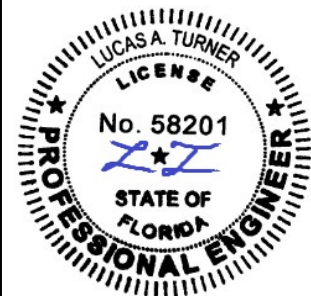

TABLE 2: P-HOOK INSTALLATION FASTENERS TABLE

ID	SUBSTRATE TYPE	ANCHOR TYPE	MIN. EDGE DISTANCE	MIN. EMBED.	MIN. ON-CENTER SPACING
R	CONCRETE (3.05 KSI MIN)	3/16" DEWALT ULTRACON+ COATED CARBON STEEL	1"	1"	3"
S	HOLLOW OR GROUT-FILLED CMU (ASTM C-90)	3/16" DEWALT ULTRACON+ COATED CARBON STEEL	1"	1-1/4"	3"
T	2x MIN. SPRUCE-PIN-FIR WOOD (G=0.42 MIN)	#8 GRADE 5 STEEL WOOD SCRW	1"	1-1/4"	3"
U	16 GAUGE (0.060") MIN. STEEL STUD, 33 KSI MIN. YIELD	#10-16 ITW-TEKS, DEWALT DRIL-FLEX, OR HILTI KWIK-FLEX SELF DRILLING SCREW	1/2"	FULL PLUS 3 THREADS MIN.	3"
V	1/8" ALUM. 6063-T5 MIN. OR 1/8" STEEL 33 KSI MIN.	#10-16 GRADE 5 SELF-TAPPING/DRILLING SCREW	1/2"	FULL PLUS 3 THREADS MIN.	3"

NOTES: -ALL SCREWS SHALL BE PAN OR HEX WASHER HEAD.
-PRE-DRILLING FOR ANCHORS INTO WOOD IS RECOMMENDED.
-CONCRETE/MASONRY SHALL NOT BE CRACKED.

TITLE: PERSPECTIVE MULTI-SLIDE PD HVHZ NON-IMPACT P-HOOK ANCHOR LAYOUT DETAILS & TABLE 2	DATE			
	BY			
NO.	REVISION DESCRIPTION			
DATE: 09/18/23	DWN BY: LMH	CHK BY: SAS	SCALE: NTS	



12/17/2023
LUCAS A. TURNER, P.E.
FL PE # 58201
TURNER ENGINEERING & CONSULTING, INC.
(COA # 29779)
2428 OLD NATCHEZ TRACE TRAIL, CAMDEN, TN 38320
PH. 941-380-1574

FL#: **41161**

DWG #: **PGW347**

SHEET: **25 OF 29**

SPLICE DETAILS

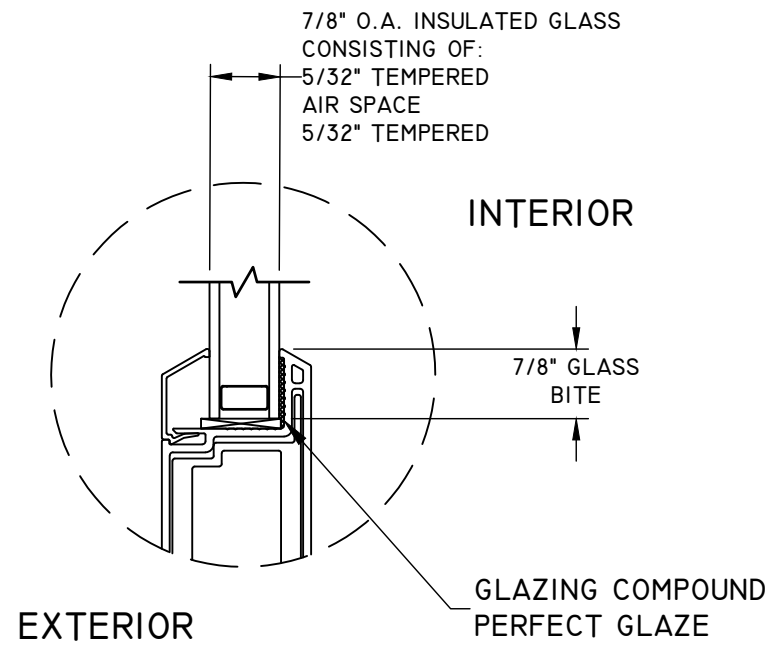

GLAZING DETAIL 1

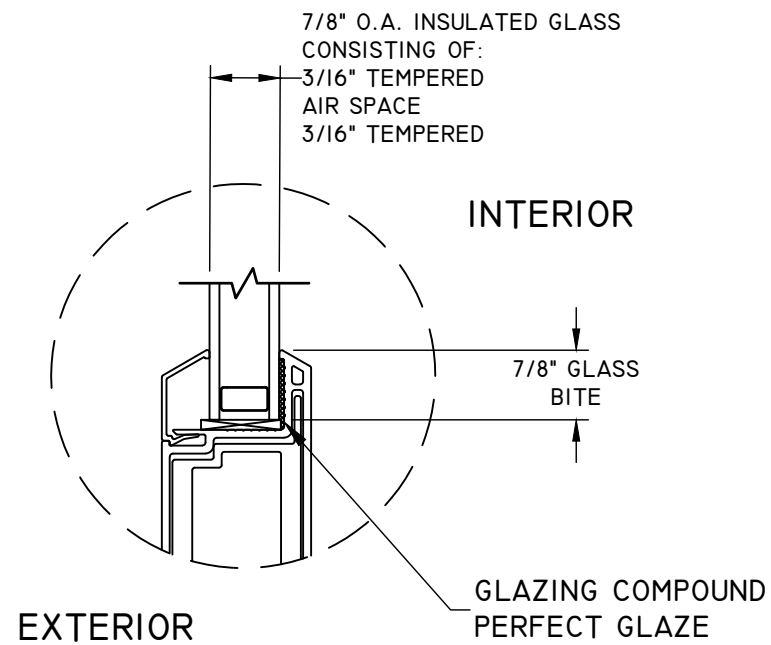

GLAZING DETAIL 2

GLAZING NOTE:
GLASS THICKNESS AND TYPE SHALL COMPLY WITH
ASTM E-1300 GLASS CHART REQUIREMENTS.

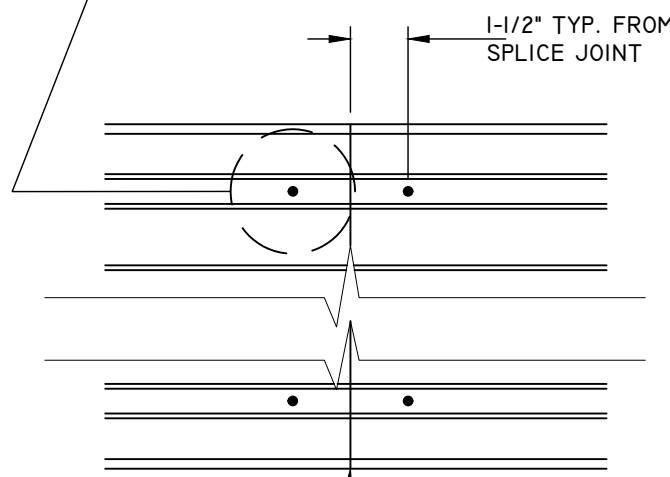
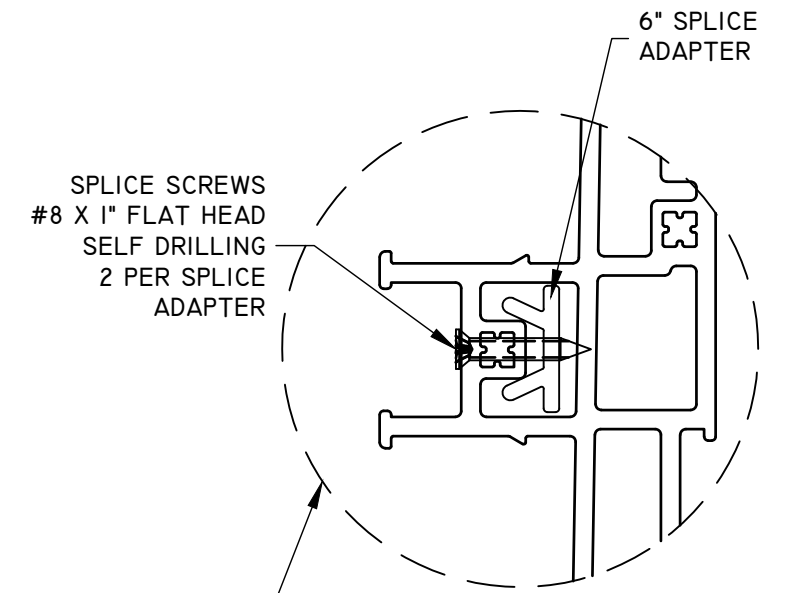

APPLY SILICONE TO THE FACE
OF FRAME PROFILE BEFORE
CONNECTING SPLICE.

TITLE: PERSPECTIVE MULTI-SLIDE PD HVHZ NON-IMPACT GLAZING DETAILS & SPLICE DETAILS	DATE			
	BY			
NO.	REVISION DESCRIPTION			
DATE: 09/18/23	DWN BY: LMH	CHK BY: SAS	SCALE: NTS	

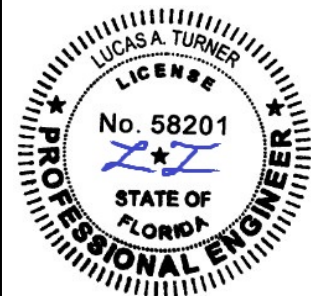

12/17/2023
LUCAS A. TURNER, P.E.
FL PE # 58201
TURNER ENGINEERING &
CONSULTING, INC.
(COA # 29779)
2428 OLD NATCHEZ TRACE
TRAIL, CAMDEN, TN 38320
PH. 941-380-1574

FL#: **41161**
DWG #: **PGW347**
SHEET: **26 OF 29**

NAIL FIN SUPPLEMENTAL PATTERN - HEAD AND SILL CENTERED AT INTERLOCK / ASTRAGAL

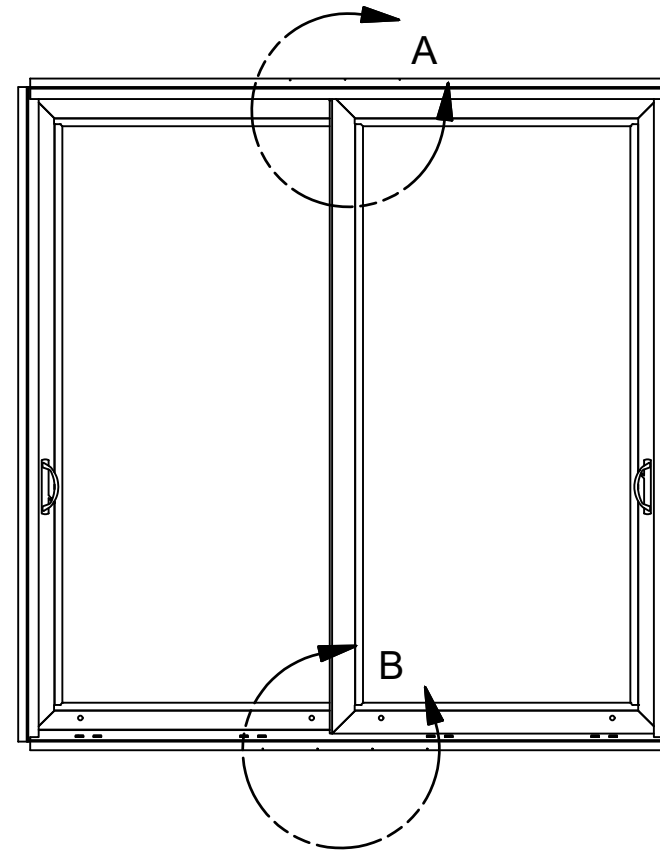
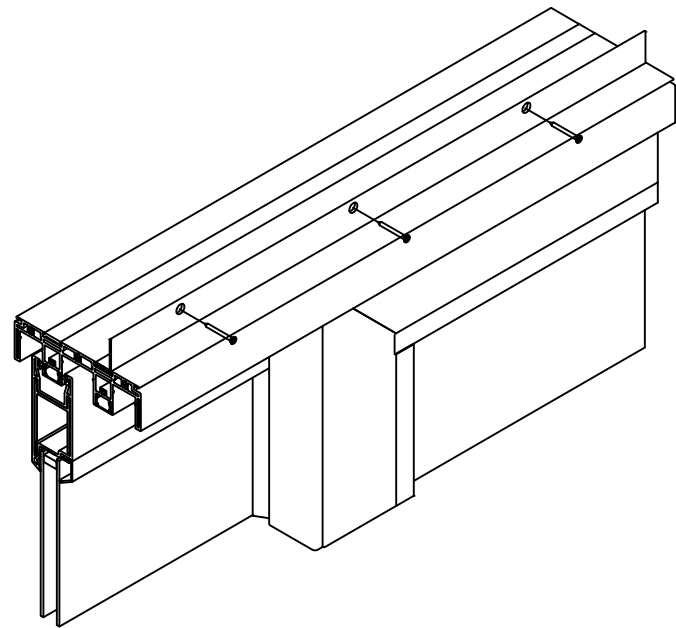

PRE-DRILL 3 - 1/8" NAIL
FIN INSTALLATION HOLES.

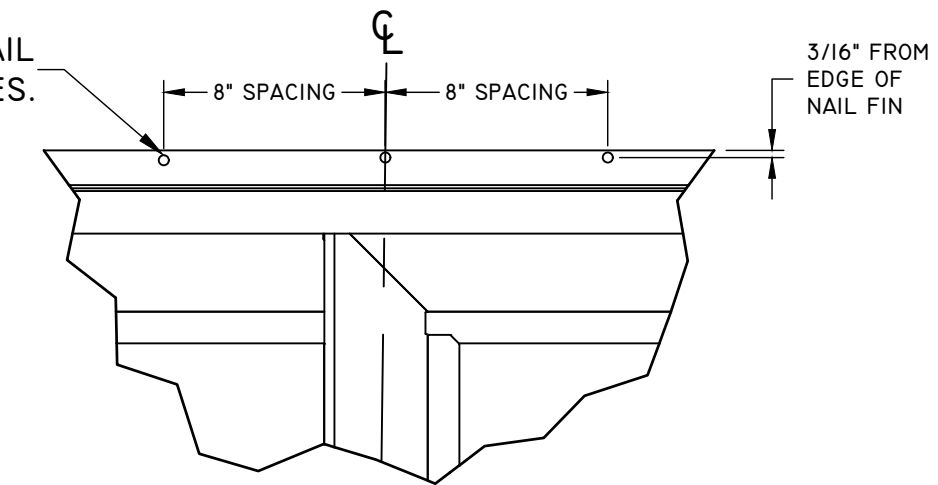

DETAIL A

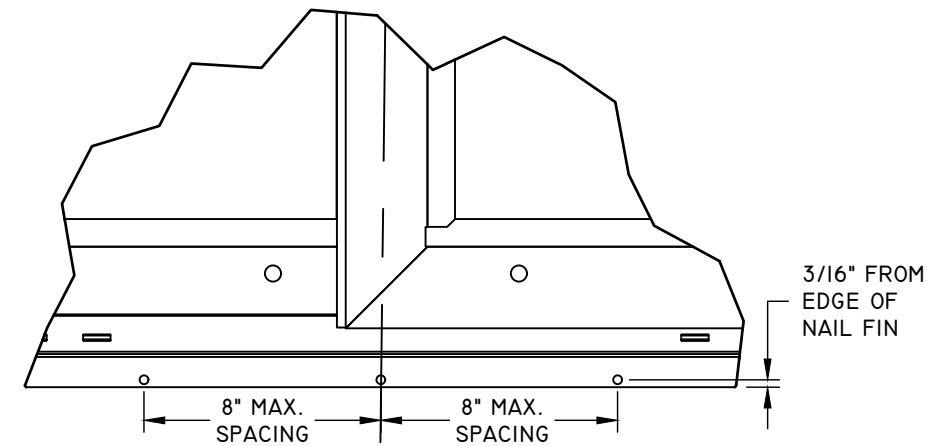

DETAIL B

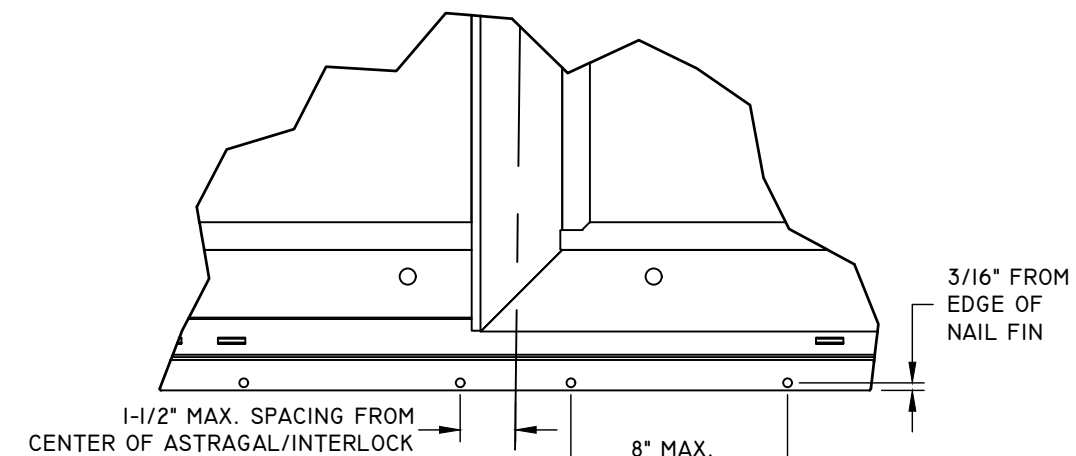

DETAIL B - ALTERNATE
2-TRACK SILL ONLY

NOTE:

APPLY A CONTINUOUS BEAD OF SEALANT
TO THE INTERIOR SIDE OF NAIL FIN,
AROUND THE ENTIRE PERIMETER OF DOOR,
APPROXIMATELY 1/4" FROM THE OUTER
EDGE OF NAIL FIN.

TABLE 3: NAIL-FIN INSTALLATION FASTENERS TABLE

ID	SUBSTRATE TYPE	ANCHOR TYPE	MIN. EDGE DISTANCE	MIN. EMBED.	MIN. ON-CENTER SPACING
X	2x MIN. SPRUCE-PIN-FIR WOOD (G=0.42 MIN)	#8 GRADE 5 STEEL WOOD SCRW	5/8"	1-1/2"	3"
Y	16 GAUGE (0.060") MIN. STEEL STUD, 33 KSI MIN. YIELD	#10-16 ITW-TEKS, DEWALT DRIL-FLEX, OR HILTI KWIK-FLEX SELF DRILLING SCREW	1/2"	FULL PLUS 3 THREADS MIN.	3"
Z	1/8" ALUM. 6063-T5 MIN. OR 1/8" STEEL 33 KSI MIN.	#10-16 GRADE 5 SELF-TAPPING/DRILLING SCREW	1/2"	FULL PLUS 3 THREADS MIN.	3"

NOTES: -ALL SCREWS SHALL BE PAN OR FLAT HEAD.
-PRE-DRILLING FOR ANCHORS INTO WOOD IS RECOMMENDED.

TITLE: PERSPECTIVE MULTI-SLIDE PD HVHZ NON-IMPACT NAIL FIN SUPPLEMENTAL PATTERN	DATE			
	BY			
NO.	REVISION DESCRIPTION			
DATE: 09/18/23	DWN BY: LMH	CHK BY: SAS	SCALE: NTS	



12/17/2023
LUCAS A. TURNER, P.E.
FL PE # 58201
TURNER ENGINEERING &
CONSULTING, INC.
(COA # 29779)
2428 OLD NATCHEZ TRACE
TRAIL, CAMDEN, TN 38320
PH. 941-380-1574

FL#: 41161

DWG #: PGW347

SHEET: 27 OF 29

BILL OF MATERIALS

ITEM#	PART#	DESCRIPTION	MATERIAL
1	207973	2 TRACK HEAD & JAMB	PVC
2	207974	2 TRACK SILL	PVC
3	207975	3 TRACK HEAD & JAMB	PVC
4	207976	3 TRACK SILL	PVC
5	207977	4 TRACK HEAD & JAMB	PVC
6	207978	4 TRACK SILL	PVC
7	207979	HEAD & JAMB FILLER	PVC
8	207981	GLAZING BEAD .875" IG	PVC
9	207983	SILL COVER	PVC
10	230326	ALUMINUM INTERLOCK	6061-T6 ALUMINUM
11	207980	ASTRAGAL	PVC
12	207984	PANEL STILE & RAIL	PVC
13	230315	NAIL FIN	6063-T6 ALUMINUM
14	230316	FRAME ANCHOR PLATE	6063-T6 ALUMINUM
15	230317	ROLLER TRACK	6063-T6 ALUMINUM
16	230318	ASTRAGAL REINFORCEMENT	6063-T6 ALUMINUM
17	230319	RAIL REINFORCEMENT	6063-T6 ALUMINUM
18	230320	STILE REINFORCEMENT .125"	6063-T6 ALUMINUM
19	230322	STILE REINFORCEMENT .375"	6063-T6 ALUMINUM
20	230324	1-3/4" SILL RISER 50	6063-T6 ALUMINUM
21	230198	SPLICER ADAPTER	6063-T6 ALUMINUM
22	240016	FIXED PANEL CLIP	6063-T6 ALUMINUM
23	230332	P-HOOK	6063-T6 ALUMINUM
24	230333	POCKET DOOR T-BASE	6063-T6 ALUMINUM
25	420098	SILL TRACK COVER	SS
26	610027	PERFECT GLAZE HOT MELT BACK-BEDDING	
27	600162	.187 x .370 WEATHERSTRIP PILE	
28	600161	.187 x .300 WEATHERSTRIP PILE	
29	440184	#12 x 1" PHIL PH 18-8 SELF DRILLING SCREW	SS
30	440199	#12 x 1" PH PH SS SCREW PAINTED	SS
31	620055	1/16" X 1-1/16" X 2" SETTING BLOCK	NEOPRENE
32	620056	1/8" X 1-1/16" X 2" SETTING BLOCK	NEOPRENE
33		QUANEX SUPER SPACER PREMIUM	

TITLE: PERSPECTIVE MULTI-SLIDE PD HVHZ NON-IMPACT BILL OF MATERIAL	DATE			
	BY			
	REVISION DESCRIPTION			
	NO.			
DATE:	DWN BY:	CHK BY:	SCALE:	
09/18/23	LMH	SAS	NTS	



12/17/2023
LUCAS A. TURNER, P.E.
FL PE # 58201
TURNER ENGINEERING &
CONSULTING, INC.
(COA # 29779)
2428 OLD NATCHEZ TRACE
TRAIL, CAMDEN, TN 38320
PH. 941-380-1574

FL#: **41161**
DWG #: **PGW347**
SHEET: **28 OF 29**

1 2 TRACK HEAD & JAMB
PVC

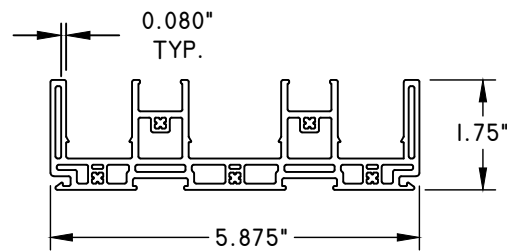

2 2 TRACK SILL
PVC

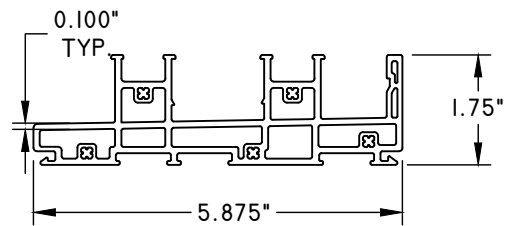

3 3 TRACK HEAD & SILL
PVC

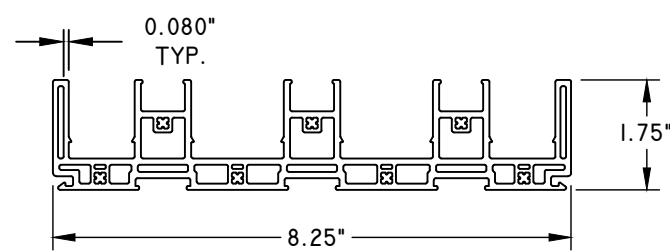

4 3 TRACK SILL
PVC

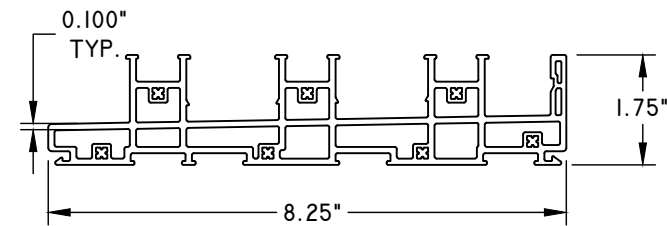

5 4 TRACK HEAD & JAMB
PVC

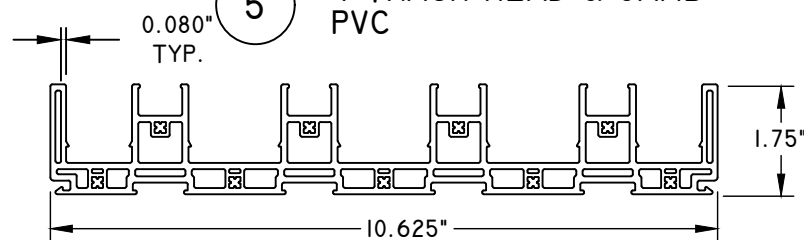

6 4 TRACK SILL
PVC

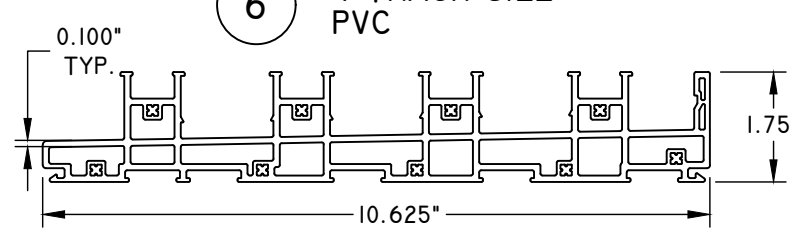

7 HEAD & SILL TRACK FILLER
PVC

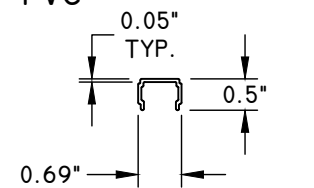

8 GLAZING BEAD
PVC

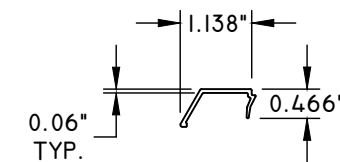

9 SILL COVER
PVC

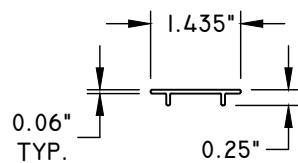

10 INTERLOCK
ALUMINUM

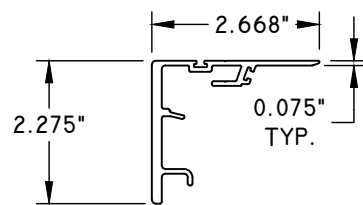

11 ASTRAGAL
PVC

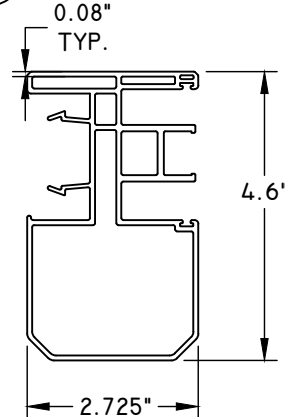

12 PANEL STILE & RAIL
PVC

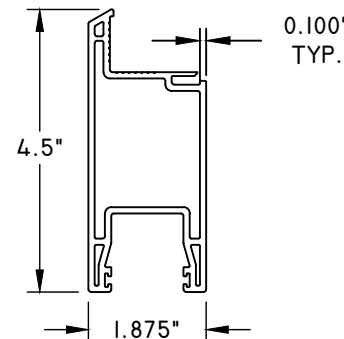

13 NAIL FIN
ALUMINUM

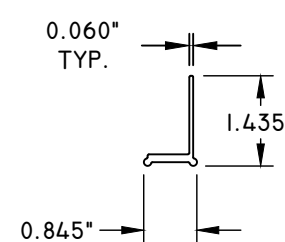

14 FRAME ANCHOR PLATE
ALUMINUM

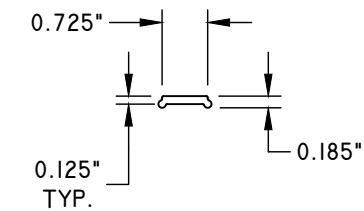

15 ROLLER TRACK
ALUMINUM

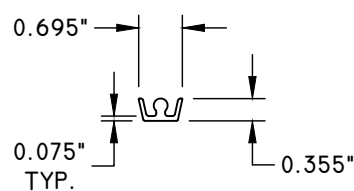

16 ASTRAGAL REINFORCEMENT
ALUMINUM

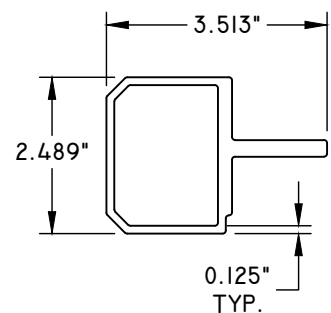

17 RAIL REINFORCEMENT
ALUMINUM

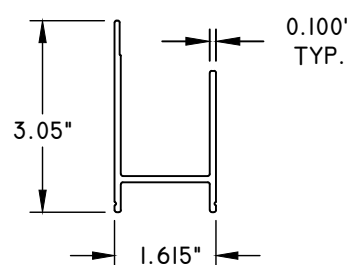

18 STILE REINFORCEMENT .125"
ALUMINUM

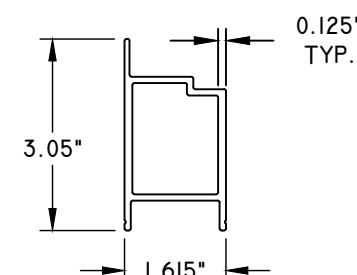

19 STILE REINFORCEMENT .375"
ALUMINUM

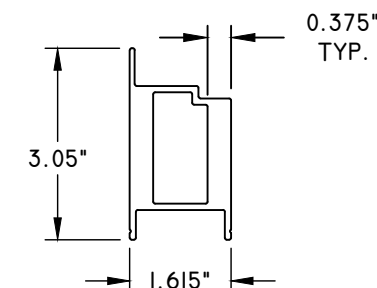

20 SILL RISER 50
ALUMINUM

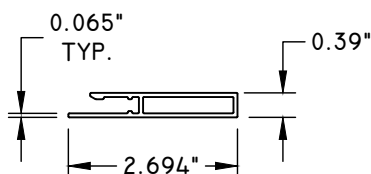

21 SPLICE ADAPTER
ALUMINUM

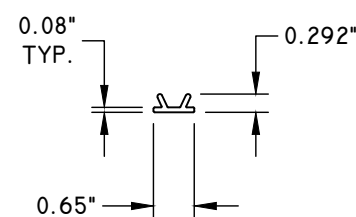

22 FIXED PANEL CLIP
ALUMINUM

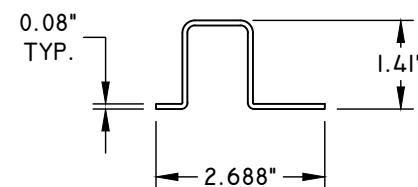

23 P-HOOK
ALUMINUM

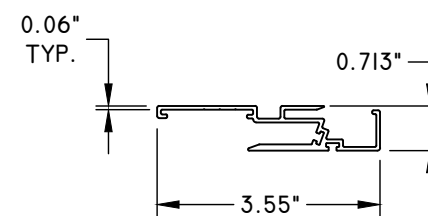

24 POCKET DOOR T-BASE
ALUMINUM

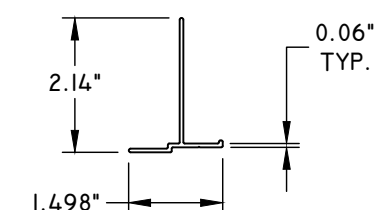

TITLE: PERSPECTIVE MULTI-SLIDE PD HVHZ NON-IMPACT COMPONENTS	DATE			
	BY			
	REVISION DESCRIPTION			
NO.				
DATE: 09/18/23	DWN BY: LMH	CHK BY: SAS	SCALE: NTS	

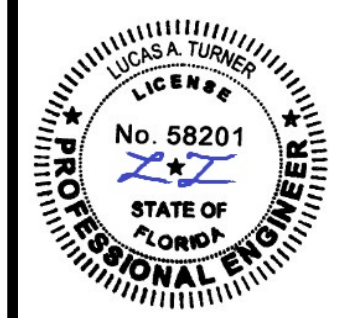

12/17/2023
LUCAS A. TURNER, P.E.
FL PE # 58201
TURNER ENGINEERING &
CONSULTING, INC.
(COA # 29779)
2428 OLD NATCHEZ TRACE
TRAIL, CAMDEN, TN 38320
PH. 941-380-1574

FL#: **41161**
DWG #: **PGW347**
SHEET: **29 OF 29**